

Préperçage de positionnement
Peg position and space requirements

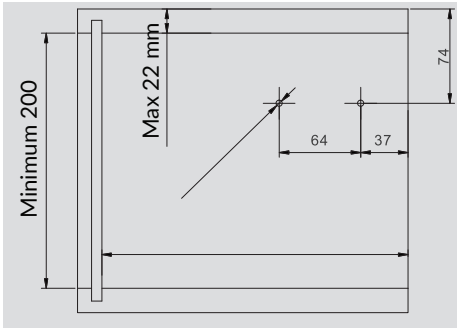

Hauteur intérieur du caisson (min 200)
Épaisseur maximum du dessus 22 mm
Inside cabinet height (min. 200)
Top maximum thickness 22 mm

Fixation de la plaque de montage dans la porte
Mounting plate door assembly

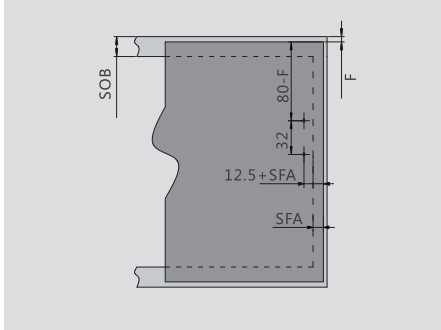

Montage avec 4 vis à bois
SFA=Recouvrement de la porte sur le côté du caisson
F= Espacement entre les portes
Wood screws (4) for wood door
SFA= Door overlay of the side panel.
F= Gap between doors

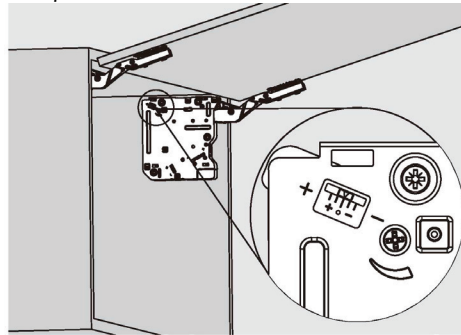

Dimensions de montage d'installation
Fixing position

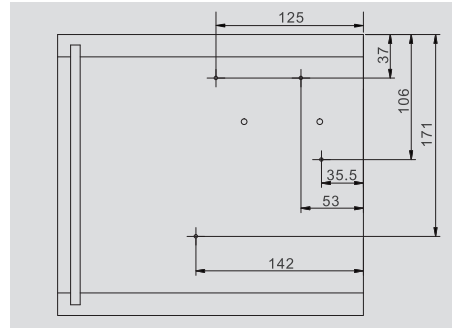

Fixation avec vis à bois 4 x 38 mm
Mounting with 4 x 38 mm wood screws

Dégagement pour moulure de tête
Crown moulding clearance

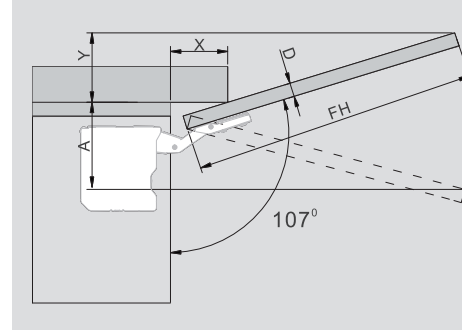

D (mm)	16	19	22	26	28
X (mm)	70	58	49	35	26
Ouverture à 107° 107° opening	Espace requis (mm) Space requirement (mm) $Y = FH \times 0.29 - 15 + D$				

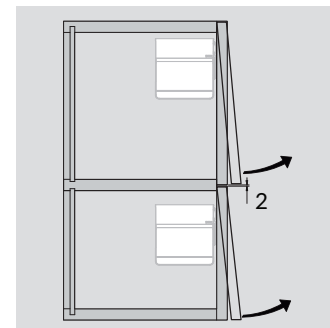

Espacement minimum entre les portes (2 mm)
Minimum gaps between the doors (2 mm)

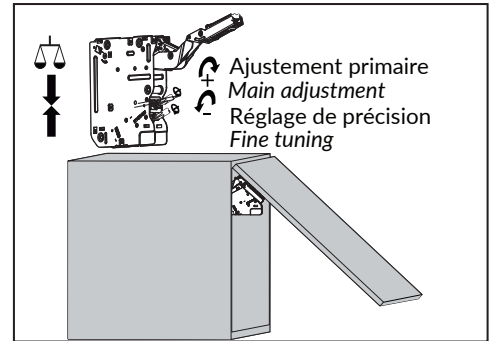

Réglage de la position arrêté de la porte
Door stay put adjustment

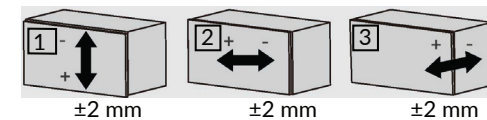
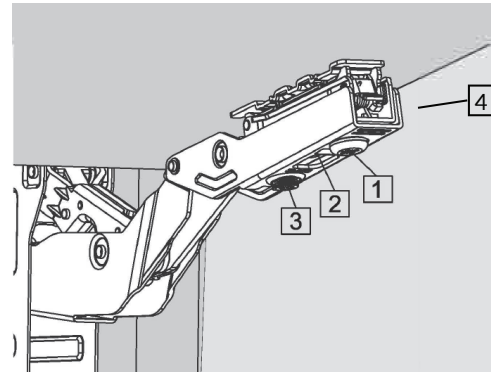

4 Clip pour démonter la porte.
Door removal clip

"-" Pour réduire le temps de freinage de la fermeture, tourner la vis dans le sens horaire.
" +" Pour augmenter le temps de freinage de la fermeture, tourner la vis dans le sens antihoraire.

"-" Reducing soft-closing time
(turn adjustment screw clockwise)

"+" Increasing soft-closing time
(turn adjustment screw counter-clockwise)

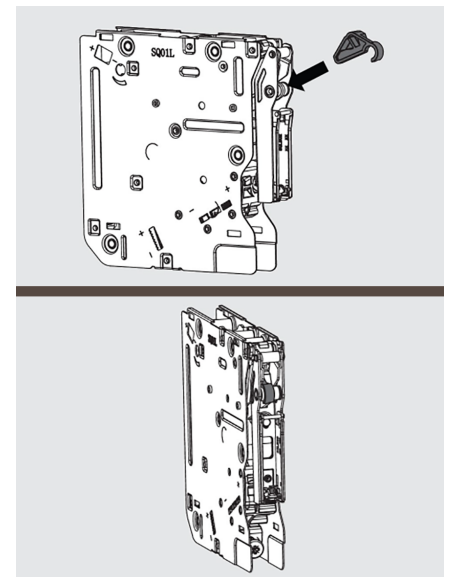

Installation du limiteur d'angle, 75° ou 100°.
Angle limiter installation 75° or 100°.

Assemblage dans le caisson

Mounting in the cabinet

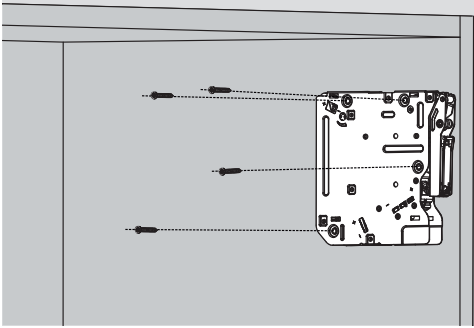

Montage dans le caisson avec vis euro
Cabinet mounting with euro screw

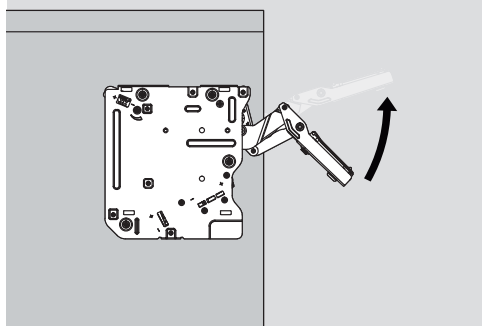

Attention lors de l'ouverture
Caution when opening arm

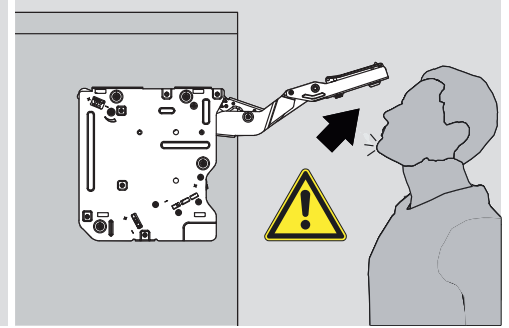

Le bras de ce système est sous tension et peut causer des blessures. Ne pas le redescendre sans la porte.

The arm of this device could spring up and cause injury. Do not push the arm down without the door attached.

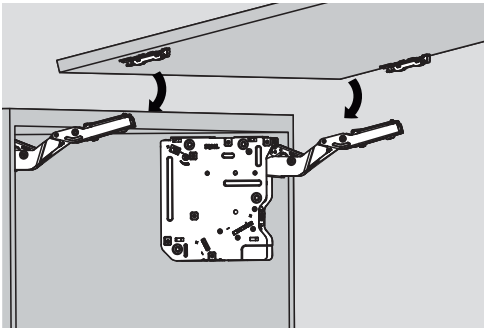

Assemblage de la porte
Door assembly

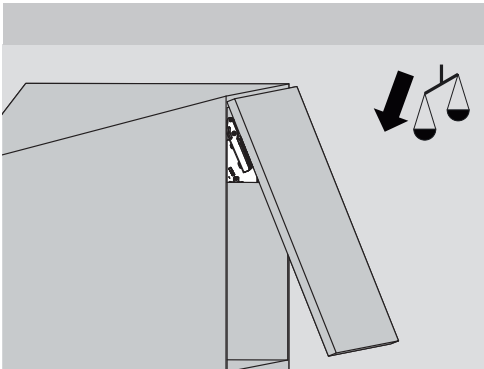
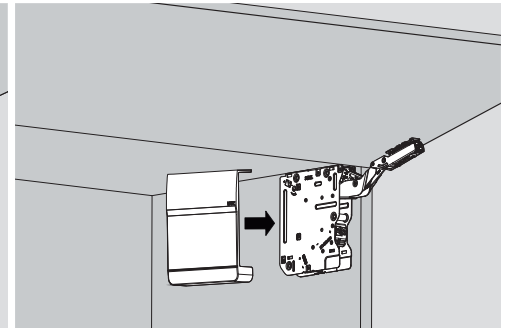
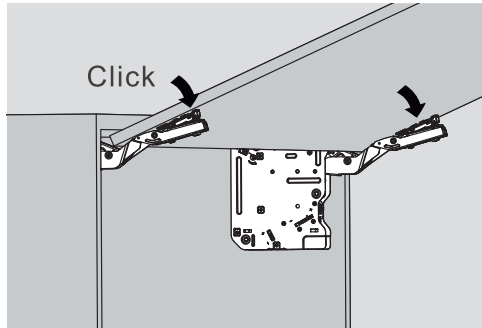

Réglage de la position arrêté de la porte
Hovering adjustment

