

Dimensions minimale requises  
Minimum displacement required

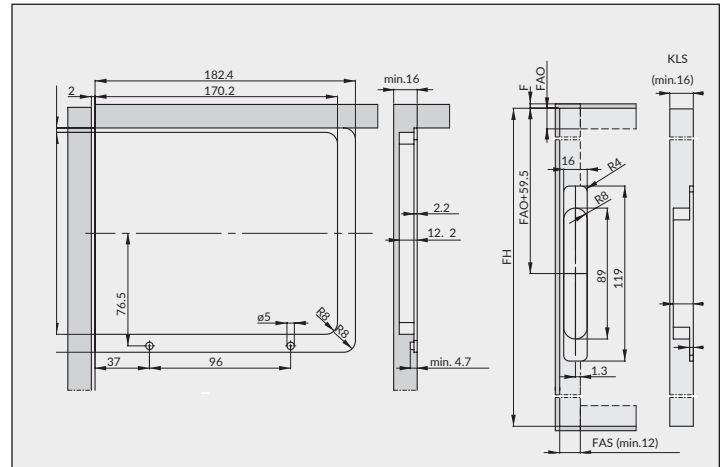

Machinage pour montage encastré  
Side and door machining for inset mounting

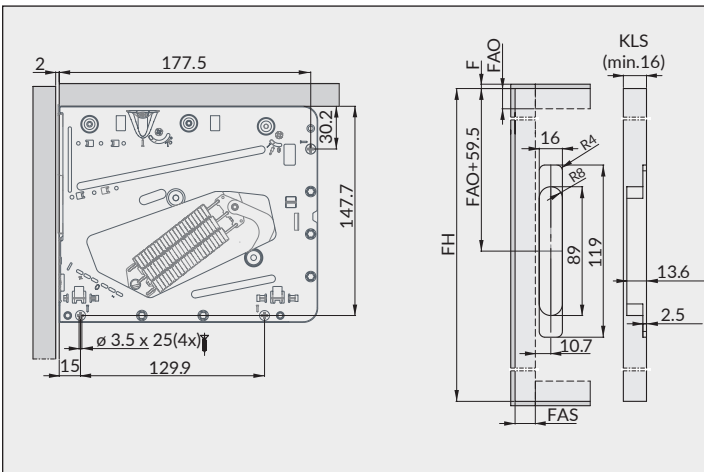

Montage en surface et machinage de la porte  
Applied mounting and door machining

		FAO					
		2	15	17	19	21	22
KLS	16	1	1	1	1	1	1
	18	2.5	1	1	1	1	1
	19	3.5	1	1	1	1	1
	20	5	1	1	1	1	1
	21	6.5	1	1	1	1	1
	22	7.5	1	1	1	1	1
	24	10.5	1.5	1	1	1	1
	26	13	3	2.5	1.5	1	1
32		21	8	7	6	5.5	5
		F					

Tableau de recouvrement  
Overlay chart

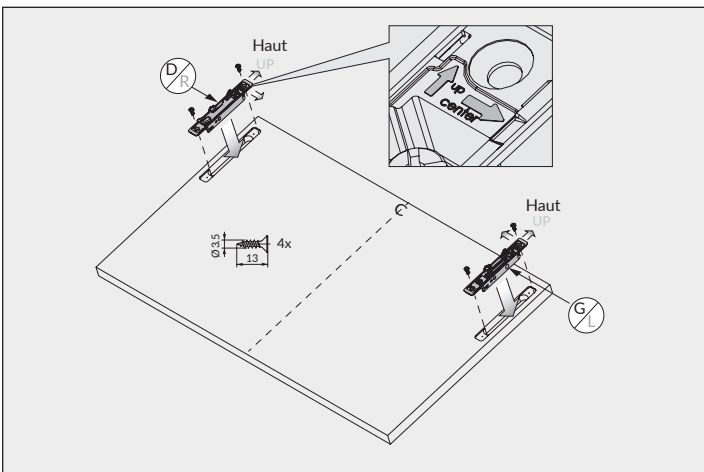

Montage des plaques dans la porte  
Mounting plates in the door

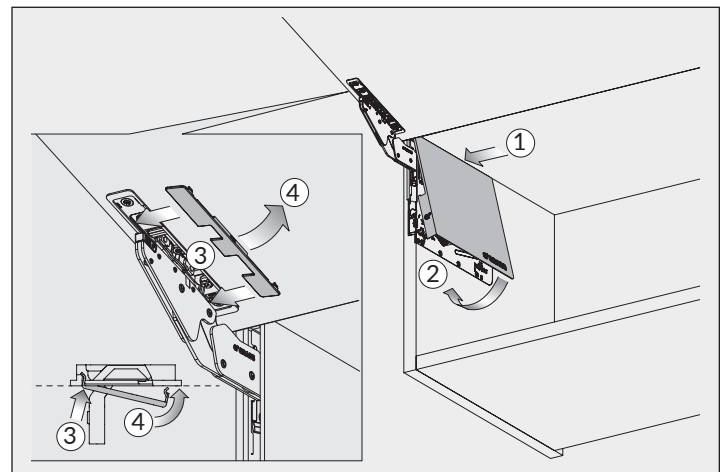

Montage des caches  
Cover caps application

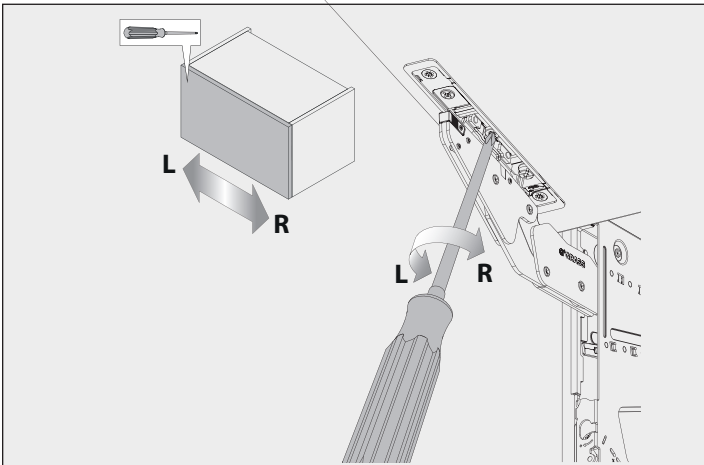

Réglage de la porte gauche droite  
Right and left door adjustment

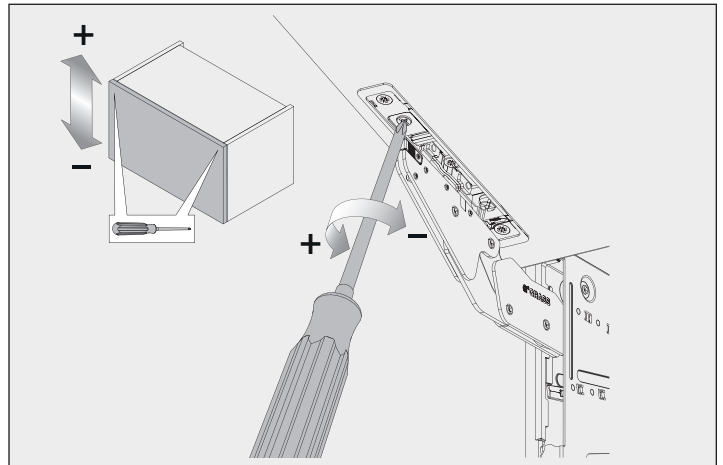

Réglage de la porte haut et bas  
Door adjustments up and down

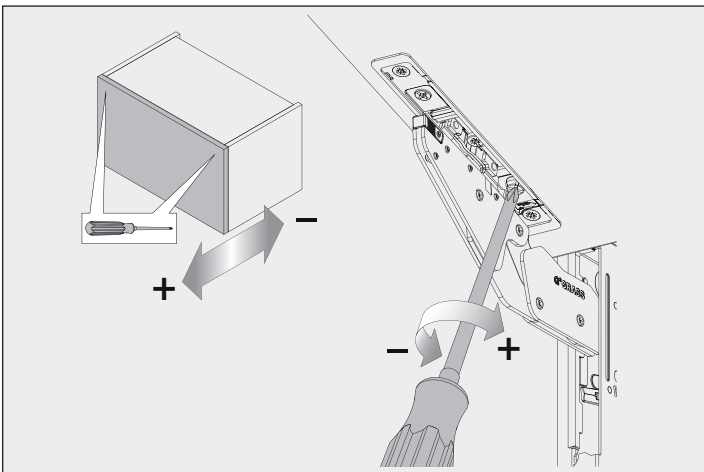

Réglage de la porte avant arrière  
Door depth adjustment

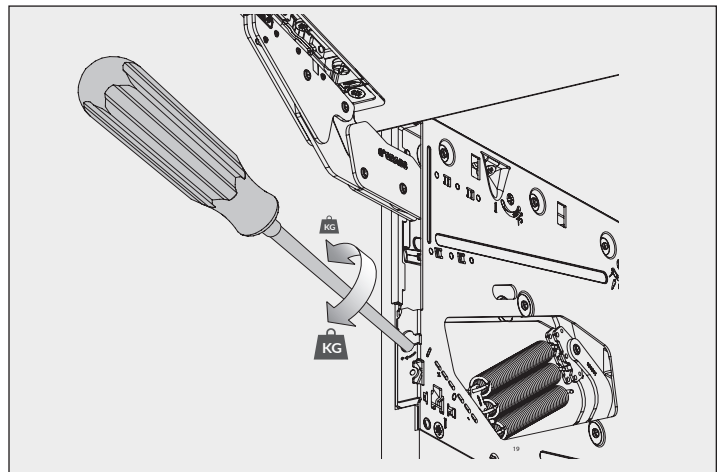

Régler la tension de la porte  
Door tension adjustment

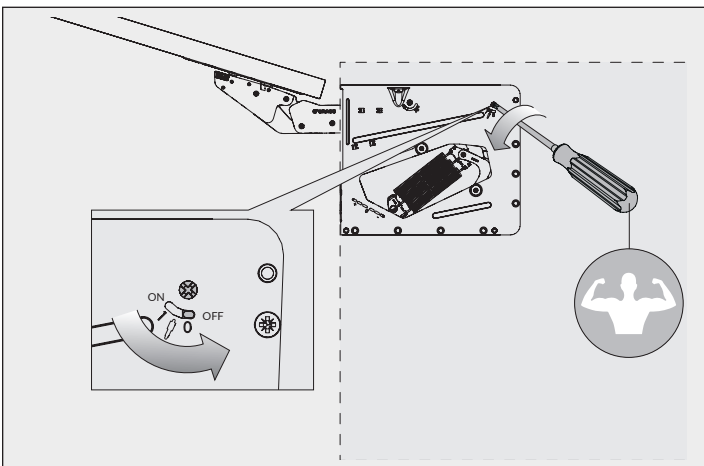

Désactiver la fermeture amortie  
Door angle adjustment

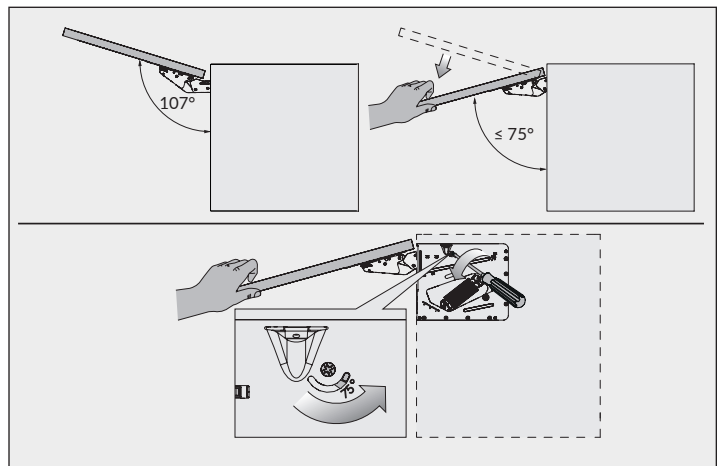

Ajustement de l'angle de l'ouverture  
Door angle adjustment