

LFT=Largeur du fond de tiroir / Drawer bottom width
LN = Longueur nominale / Nominal length
LIC=Largeur intérieure caisson / Inside cabinet width

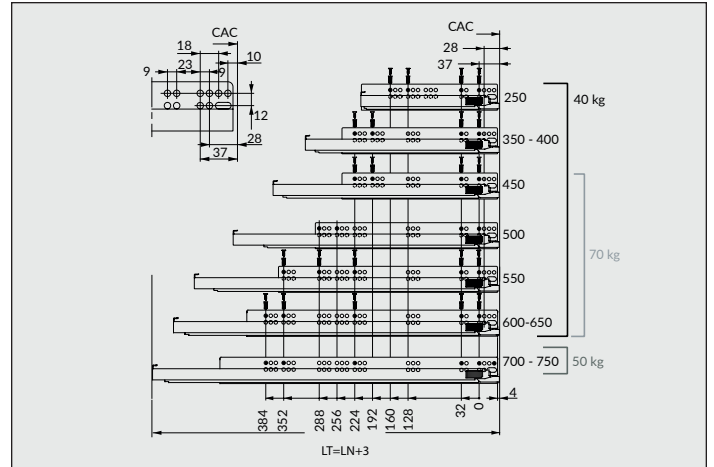

LT=Longueur totale / total length
CAC= chant avant du caisson / cabinet front edge

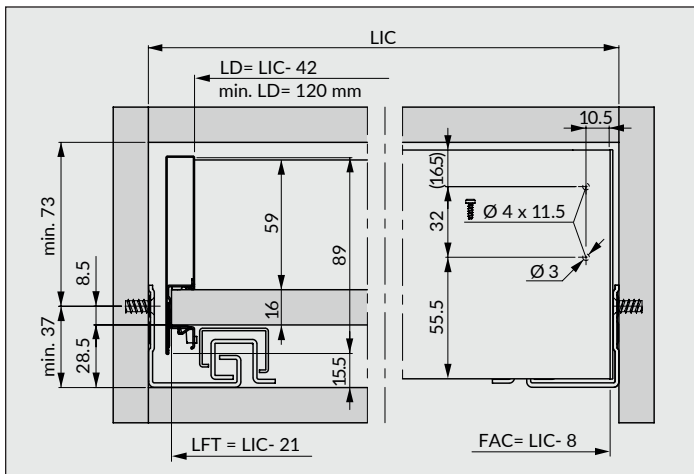

LIC = Largeur intérieure caisson / Inside cabinet width
LFT = Largeur fond du tiroir / Inside cabinet width
LD = Largeur du dos / Drawer back width

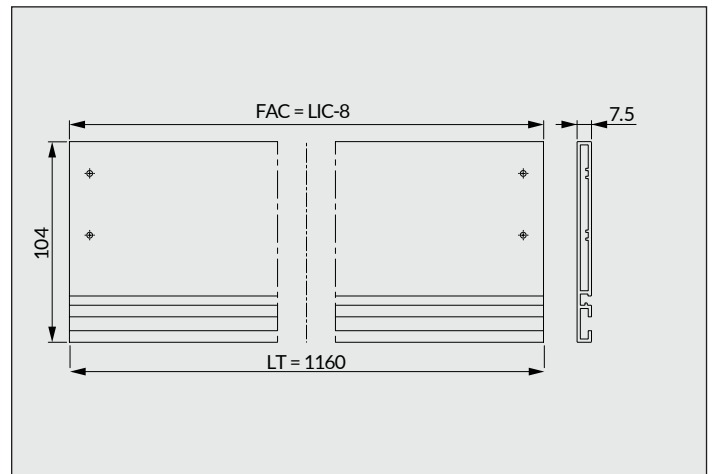

FAC=façade d'aluminium à recouper
FAC=Aluminum drawer front cut to size

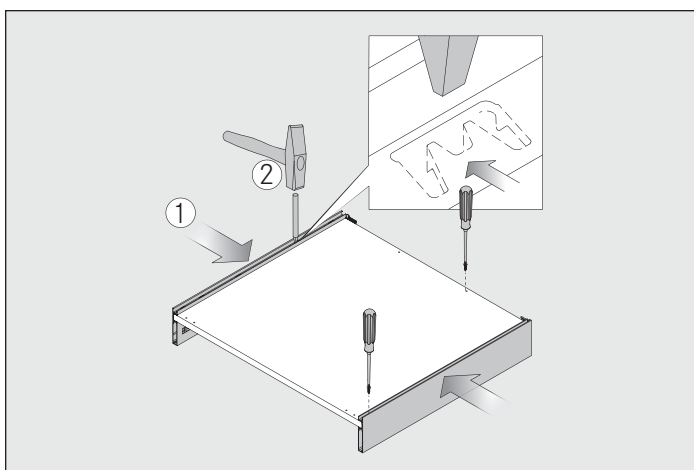

Vissez le fond ou fixez-le avec les agrafes à enfoncer.
Screw the bottom or crimped it with the knock in claws.

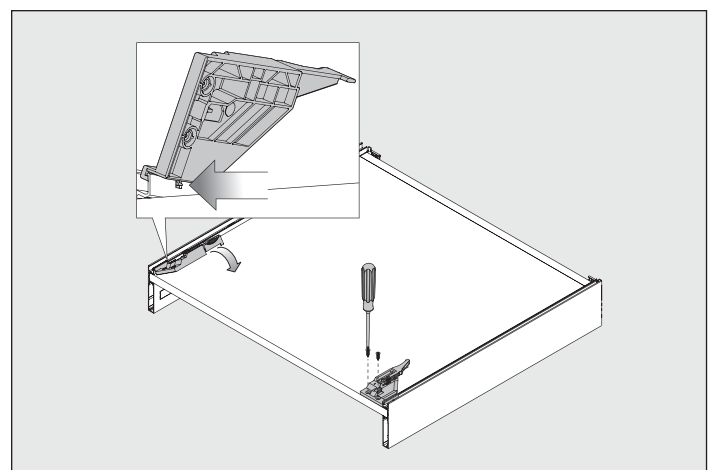

Visser les attaches de coulisses sous le tiroir.
Screw the slide brackets under the drawer.

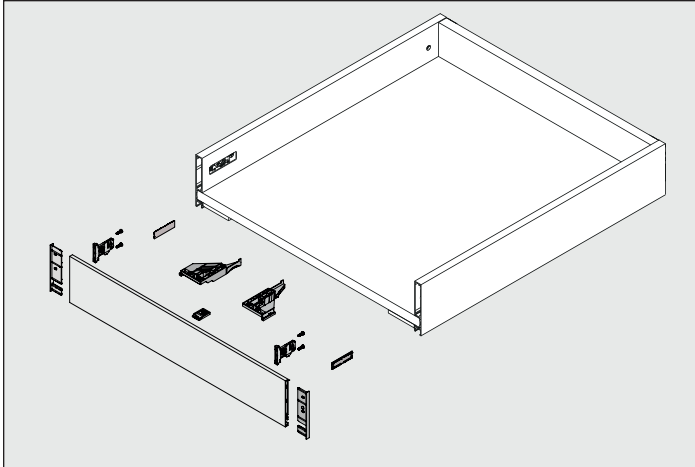

Fixer les attaches et les embouts sur la façade d'aluminium.
Fix the front brackets and endcap on the aluminum drawer front.

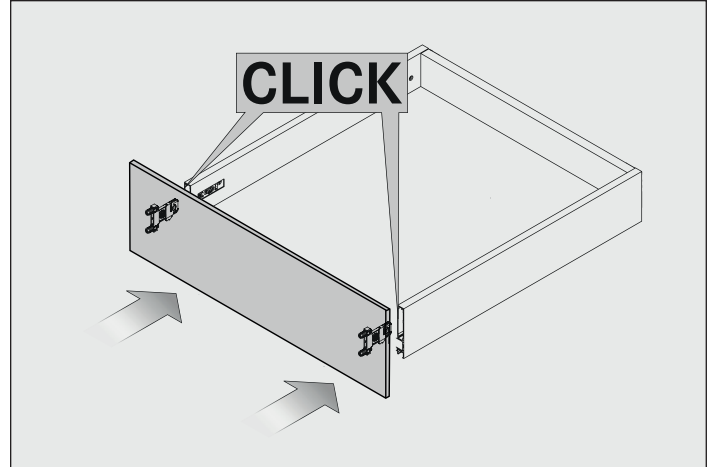

Monter la façade sur le tiroir
Mount the front on the drawer

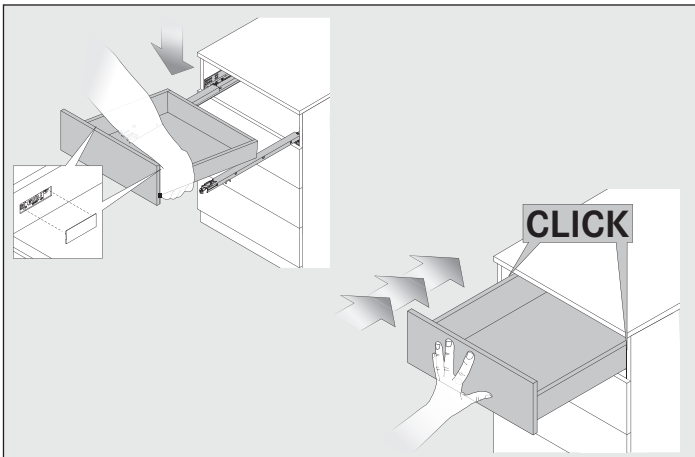

Tirer les coulisses, poser le tiroir dessus et refermer pour clipser le tiroir sur les coulisses
Extend the slides, put the drawer on them and close the drawer to clip it to the slides.

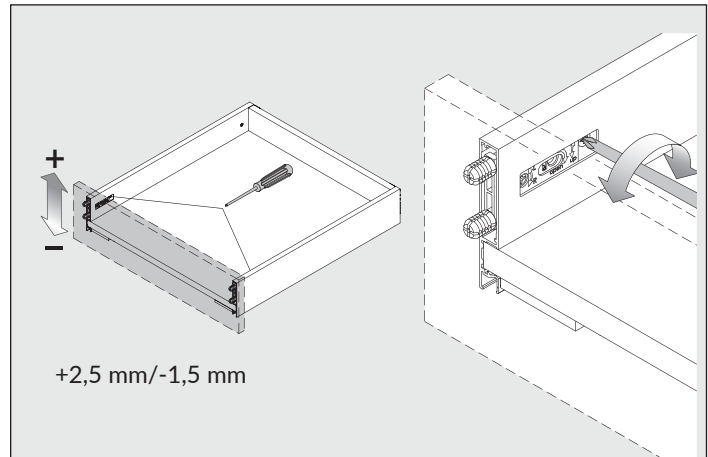

Réglage de la hauteur de la façade
Drawer front height adjustment

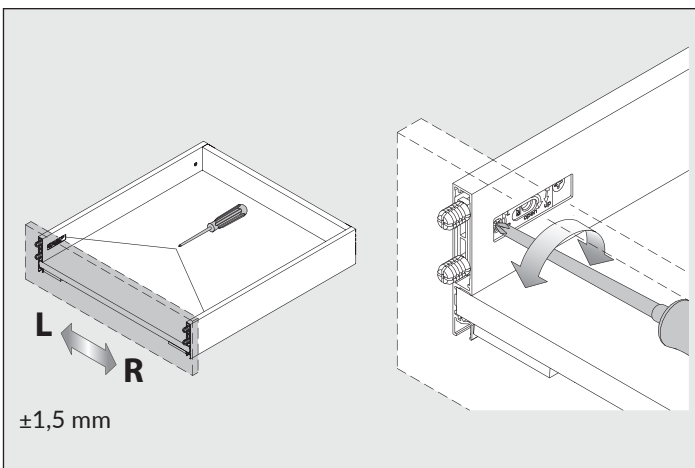

Réglage latéral, les deux côtés doivent être ajustés
Lateral adjustments, adjust both sides.

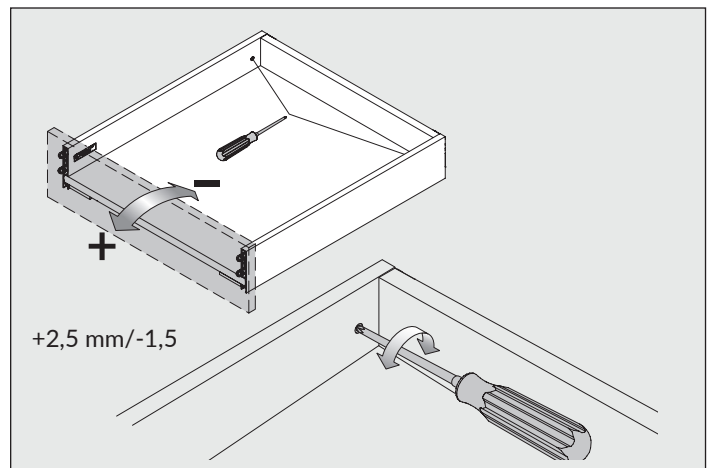

Réglage de l'inclinaison
Tilt adjustment