

LFT= Largeur du fond de tiroir/ Drawer bottom width  
LN = Longueur nominale / Nominal length  
LIC=Largeur intérieure caisson / Inside cabinet width

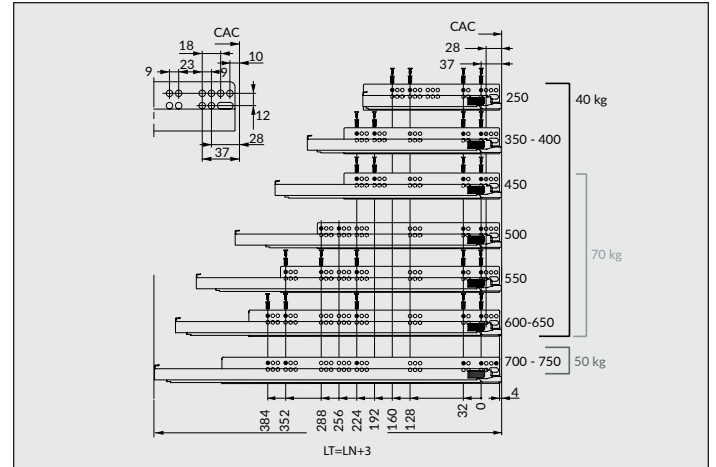

Longueur totale / total length  $LT = LN + 3$

CAC= chant avant du caisson / cabinet front edge

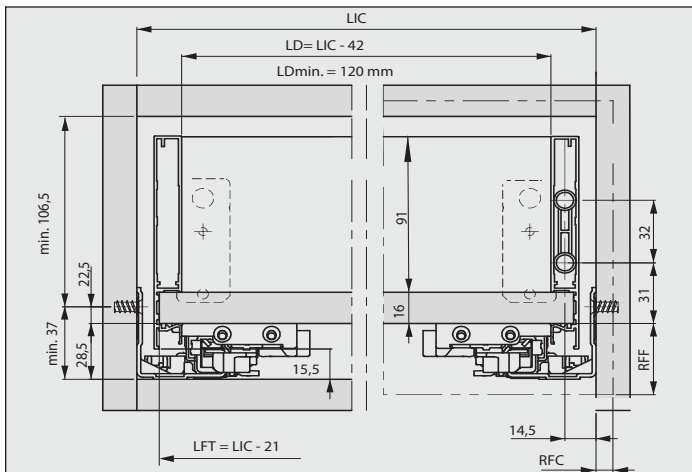

LIC = Largeur intérieure caisson / Inside cabinet width  
LFT = Largeur fond du tiroir / Inside cabinet width  
LD = Largeur du dos / Drawer back width

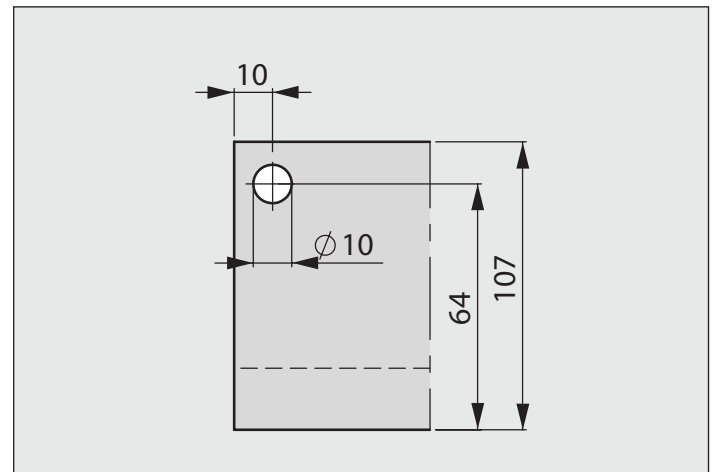

Perçage et dimensions du dos

Back dimensions and drilling.

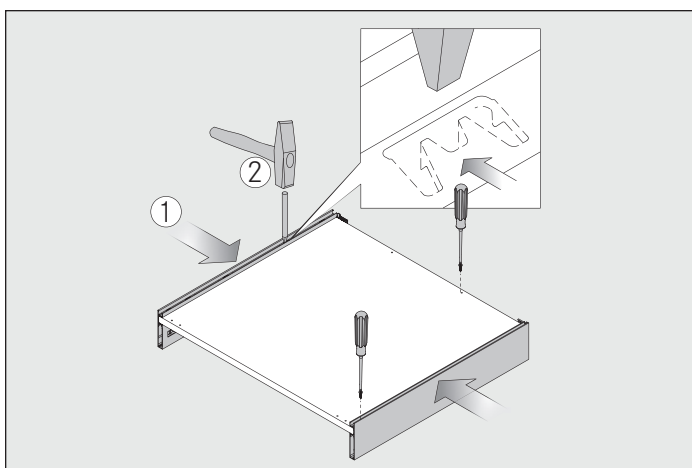

Vissez le fond ou fixez-le avec les agrafes à enfoncer.  
Screw the bottom or crimped it with the knock in claws.

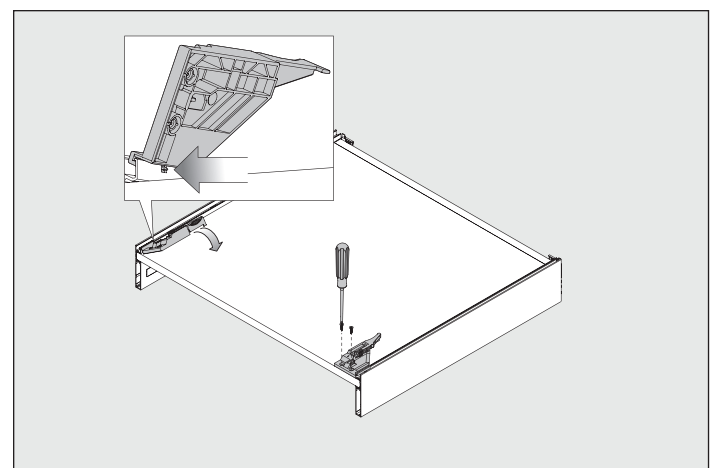

Visser les attaches de coulisses sous le tiroir.  
Screw the slide bracket under the drawer.

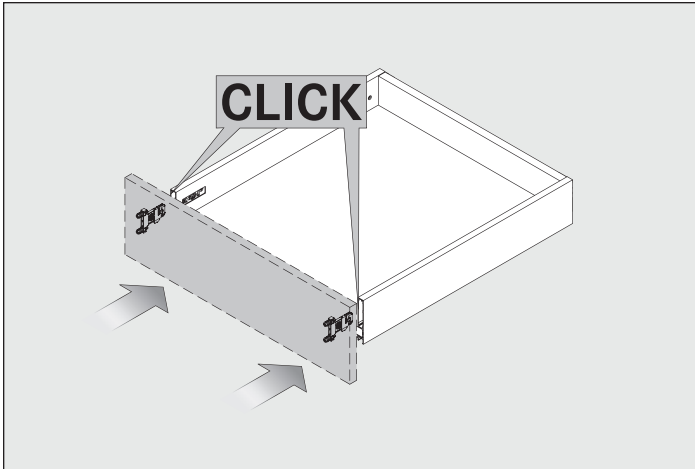

Fixer les attaches sur la façade et clipsées sur le tiroir.  
Fix the front brackets and clip them on the drawer.

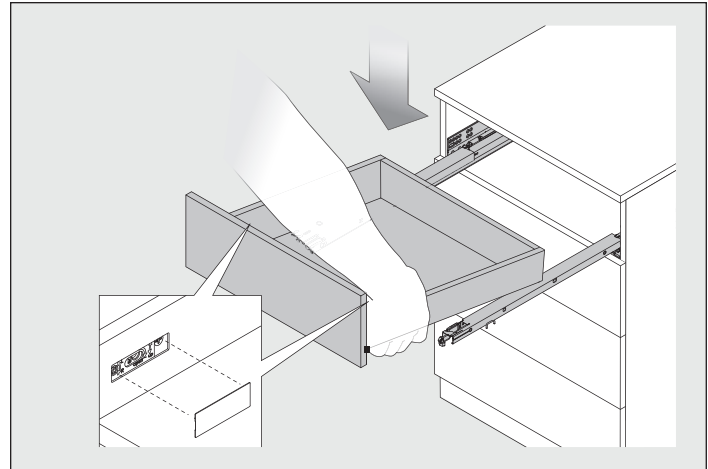

Tirer les coulisses, poser le tiroir dessus et refermer pour le clipser.  
Extend the slides, put the drawer on them and close to clip it.

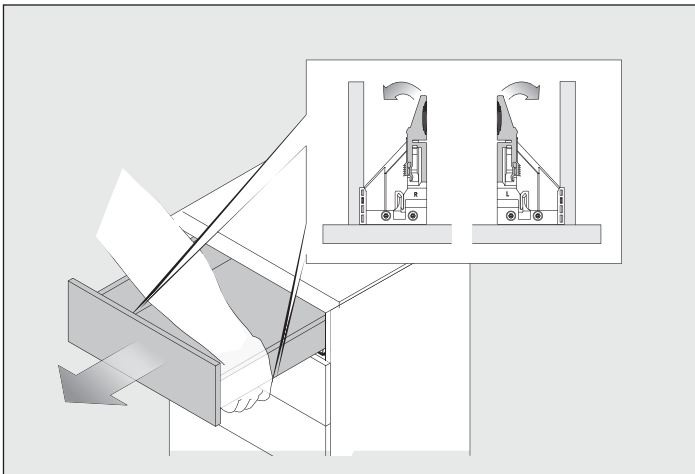

Enlèvement du tiroir sans outils.  
Drawer removal, without tool.

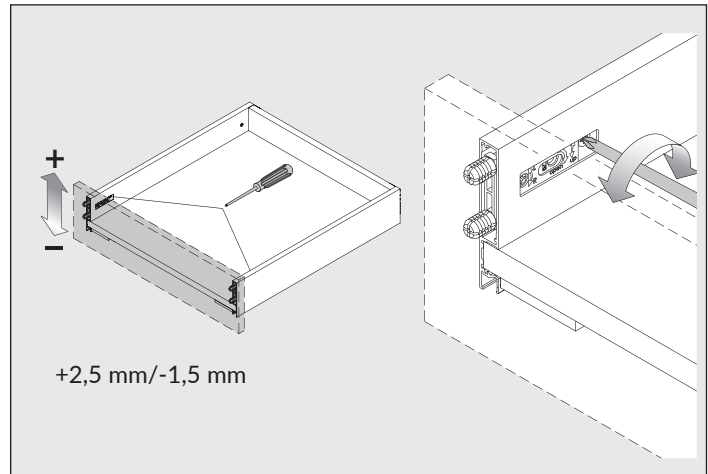

Réglage de la hauteur de la façade  
Drawer front height adjustment

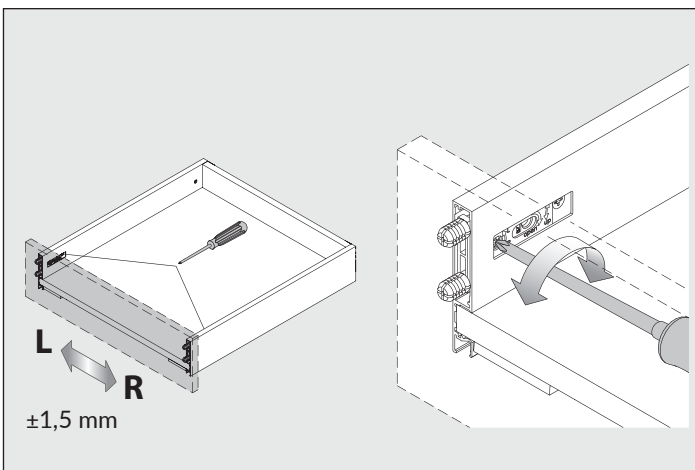

Réglage latéral, les deux côtés doivent être ajustés  
Lateral adjustment, adjust both sides.

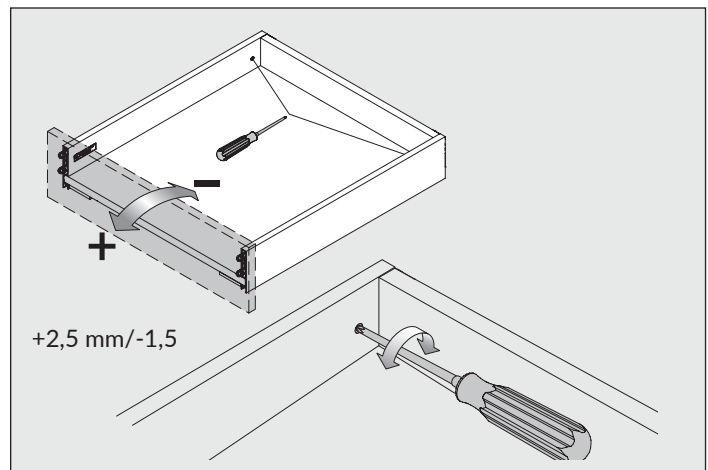

Réglage de l'inclinaison  
Tilt adjustment