

GRASS MOVEMENT SYSTEMS

TECMATOR RP

Operating Manual

 **GRASS**[®]



GRASS TECMATOR RP

Operating Manual

Table of Contents

1.0	Introduction	5
1.1	Instructions for Installers	5
1.2	Signs and Symbols in this Manual	5
1.3	Intended Use	5
2.0	Technical Data	6
2.1	Dimensions	6
3.0	Manufacturer	7
3.1	Copyright.....	7
4.0	Warranty conditions	7
5.0	Safety instructions	8
5.1	Residual Risks in Accordance with EN ISO 10200-1	8
5.2	Hazards and Safety Measures.....	9
5.3	Safety Equipment	10
5.4	Sticker Description	10
5.5	Purpose.....	10
5.6	Identification of the Product	10
6.0	Standard specification	11
7.0	Description of machine parts	12
7.1	Overall View with Part Numbering.....	12
8.0	Gearbox hole patterns TECMATOR RP	13
9.0	Description of the operating elements	13
10.0	Circuit diagrams	14
10.1	Pneumatic Circuit Diagram	14
10.2	Electrical Circuit Diagram	15
11.0	Transport, installation and final adjustment	16
11.1	Scope of Supply	16
11.2	Transport and Storage Conditions.....	16
11.3	Space Requirements and Ambient Conditions.....	16
12.0	Accessories	17
13.0	Commissioning	18
13.1	Pneumatic Connection.....	18
13.2	Removal of the Drop Arrestor	18
13.3	Function Te.....	18
13.4	Electrical Connection.....	19
14.0	Working with the TECMATOR RP	20
14.1	Requirements for the Operating Personnel.....	20
15.0	Set-up of the TECMATOR RP	20
15.1	Chucking the Drill Bits	20
15.2	Installing an Insertion Die	21
15.3	Setting the Drilling Depth.....	21
15.4	Setting the Drilling Distance	22
15.5	Adjustment of the Side Stops	23
15.6	Adjustment of the Hold-down Devices	23
16.0	Drilling and insertion for the Grass TIOMOS hinge.....	24
17.0	Drilling the 32 mm hole spacing.....	26
18.0	Replace machine parts	28
18.1	Replacement of Drilling Gear	28
18.2	Installing Hold-down Device Extension	29
19.0	Troubleshooting	30
20.0	Maintenance and care	31
21.0	Individual parts of the Tecmator RP.....	33
22.0	Declaration of Conformity	34

1.0 Introduction



Please read this operating manual carefully and act accordingly. Keep this operating manual for future reference or for a subsequent owner.

1.1 Instructions for Installers

The following installation and operating instructions contain important tips, instructions and recommendations for installation, commissioning and operation.

In order to ensure safe and flawless operation of the TECMATOR RP, please read and adhere to these instructions.

1.2 Signs and Symbols in this Manual

The signs and symbols in this operating manual are intended to ensure quick and safe use of the manual and the system.



Note

This sign draws attention to additional information which may be helpful when using the TECMATOR RP.



Warning of a general danger

This warning sign indicates actions which may for several reasons cause danger or impair functionality.



Warning of hazardous voltage

This warning sign indicates actions during which you will be exposed to danger due to electric shock possibly causing fatal injuries.



Action

This symbol indicates a need for action. This action facilitates correct and safe use of the machine.

1.3 Intended Use

The Grass TECMATOR RP is intended exclusively for drilling in solid wood and wood materials. Use for any other purpose is not considered an intended use. The manufacturer assumes no liability for any damage or injury resulting from such use. This risk must be borne solely by the machine owner. The intended use also implies observance of the operating manual. The machine may only be operated, maintained and repaired by trained and authorised persons. The original equipment must not be changed without the approval of Grass GmbH.

2.0 Technical Data

2.1 Dimensions

Machine table width	600 mm
Machine table height	100 mm
Machine table depth	400 mm
Overall machine height	800 mm
Overall machine depth	710 mm

Adjustment Ranges of the Machine

Drill bit length – maximum possible length	57 mm
Drill bit diameter – maximum permissible bit diameter at the cup spindle	35 mm
Drill bit diameter – maximum permissible bit diameter on all other spindles	10 mm

Other Data

Insertion force at 0.6 MPa (6 bar)	approx. 3200 N
--------------------------------------	----------------

Weights

Total weight of the TECMATOR RP standard specification	70 kg
--	-------

Electrical Connections

Motor	2 KW ; 3,000 rpm 400 V ; 50 Hz, mains protection 16 A
Connected load with 3-phase AC motors	1.1 kW

Power feeder size in accordance with the local regulations, but at least 1.5 mm.

Fuse in the power feeder with max. 1.5 x rated current according to rating plate, but max. 12 A.

Pneumatic Connections

Air connection	1/8"
Dust, water and oil-free compressed air	min. 6 bar
Max. admissible pressure in supply line	8 bar
Compressed air consumption per drilling stroke at 6 bar	1.8 l

Compressor/ tank capacity	min. 100 litres
Intake capacity	200 litres/min

Other Dimensions

Cylinder diameter	80 mm
Stroke height	140 mm

Emission Values

Noise emissions, depending on material	approx. 82 dBA
--	----------------

3.0 Manufacturer

GRASS GmbH & Co. KG
Egerländer Straße 2
64354 Reinheim
Germany

Tel. +43 / (0)5578 / 701 - 0
Fax. +43 / (0)5578 / 701 - 59
E-mail: info@grass.eu
Internet: www.grass.eu

3.1 Copyright

The copyright to this documentation lies exclusively with the manufacturer.

Any form of duplication, in whole or in part, is only permitted with the approval of the manufacturer unless the duplicated manual is necessary for operation of the Tecmator RP.

4.0 Warranty conditions

The Tecmator RP has been produced from the best material and by highly qualified staff. Continuous quality controls and test runs of each individual product ensure that the machine is delivered in a flawless and functional condition. For this reason we assume a warranty of 12 months starting from the date of delivery. Should a fault nevertheless occur in the machine, please contact your responsible dealer, presenting the invoice or delivery note.

The warranty covers purely the replacement of parts, not the necessary labour times, waiting times, consequential damage, etc.

The warranty does not cover:

- Transport damage (please report this immediately to the responsible shipping agent)
- Damaged caused by improper use
- Compensation for standstill times
- Normal wear of wear parts
- Tools
- Drill bits
- Damage resulting from failure to observe the safety regulations
- Damage resulting from improper handling of use of the TECMATOR RP for other than its intended use.
- Damage to the material being drilled
- Compensation for standstill times
- Loss of earnings due to a defective TECMATOR RP
- Assembly times, travel times, travelling expenses

5.0 Safety instructions

- It is the obligation of the machine owner or his authorised representative to ensure that the operating personnel is instructed in the use of the machine.
- Work on the electrical equipment may only be carried out by qualified and authorised electricians.
- The connecting leads for compressed air and electricity must be correctly laid and protected against damage (e.g. in cable trenches or similar routings).
- During maintenance and repair work on the machine, the machine must always be disconnected from the mains power supply (unplug the machine) and from the compressed air supply (e.g. at a quick-coupler).
- Before tool changing, gearbox changing or during work in the area of the drill bits, always turn the main switch to the “0” position.
- Use only approved and correspondingly strong tools (e.g. from the Grass GmbH product range).
- Only carbide metal or HSS drill bits with an overall length of 57 mm and a shank diameter of 10 mm may be used.
- The drill bit diameter may be max. 35 mm on the drive spindle unit and max. 10 mm on all other spindles.
- Before starting work, always check all safety equipment for completeness and function.
- Replace damaged parts only with OEM parts.
- Work particularly carefully with large workpieces that extend beyond the boundaries of the machine.
- After finishing work, always disconnect the machine from the mains power supply and secure it to prevent use by unauthorised persons.
- Always check that the mains plug is removed before adjustment of the machine and before tool changing.
- Keep the place of work and the machine clean at all times; dirtiness and untidy places of work increase the risk of accidents.
- Protect yourself from electric shock.
- Use the machine only in dry rooms, do not leave the machine standing outdoors, particularly not in the rain.
- Keep unauthorised persons away from the machine.
- The machine may only be operated by an authorised person.
- Keep your hands out of the working area of the drill bits and the insertion die arm during work.
- Wear appropriate working clothes when working with or on the machine.
- Wear safety goggles and a dust mask when working with or on the machine.
- Persons with long hair must wear a hair net; do not wear loose or wide clothing that could be caught up in moving parts of the machine.

5.1 Residual Risks in Accordance with EN ISO 10200-1

The TECMATOR RP is built to the state-of-the-art and the generally recognised safety rules and regulations. Risks to the life and limb of the operator or third parties, or impairments to the machine or other assets can nevertheless occur during use.

Residual risks exist:

- If the machine is operated by unqualified personnel
- If the machine is operated without the necessary guards
- If improper tools are used or if the tools are not correctly installed on the machine
- For the 2nd hand of the operator during drilling, insertion or clamping movements of machine parts

- If other persons are allowed to remain in the area of the operating machine
- In the event of interventions in a not correctly secured (switched off) machine
- In the event of failure to observe the prescribed working procedures
- In the event of a failure of control elements

These residual risks can be minimised if the safety instructions are observed.

Furthermore:

- During continuous series-production operation, a dust collector suction unit must be installed in accordance with the Workplace Ordinance.
- Adequate lighting must be ensured in accordance with the Workplace Ordinance.
- The machine may only be operated with functional safety guards.

5.2 Hazards and Safety Measures

Hazards and impairments to the life and limb of the operator or third parties, to the machine proper or to other assets or auxiliary materials may arise during the operation of the machine.

The manufacturer assumes no liability for such incidents!

A prerequisite for safe handling and trouble-free operation of this machine is the knowledge and understanding of the safety and operating instructions in this documentation.

Hazard	Safety measure
Release tool	➔ Chuck with clamping screw
Tool – breakage	➔ Use only branded products from the manufacturers product range. ➔ Wear personal protective equipment.
Tool – contact	➔ All tools behind transparent covers
Tool – machine contact	➔ Safety drilling depth stop
Workpiece flying out	➔ Workpiece stops, hold-down devices
Feed mechanisms	➔ No automatic feed movements
Workpiece clamping device	➔ Pictogram on the hold-down device (= insertion die arm)
Risk of collision	➔ None, as the lifting movement are slow
Drives	➔ Direct drives in completely enclosed gear housings
Tool unit	➔ Feed for lifting movement via buttons with collar without latching; ➔ Observance of the safety distances according to EN 294, depending on the risk
Controller, unexpected tool starting/ controller, unexpected lifting	➔ Electrical controller with P/E converter, ➔ Buttons with collar without latching
Controller, tool starting during insertion	➔ Monitoring of the insertion die arm with pneumatic valve
Electricity	➔ Equipment to EN 60204 Part 1, VDE 0100 or IEC 384
Noise	➔ Wear personal protective equipment

5.3 Safety Equipment

- Compressed air filter/pressure reducer against mechanical overloading of the machine, see Pneumatic circuit diagram chapter 10.1
- Thermal overload protection for the electric motor, see Electrical circuit diagram chapter 10.2
- Controllable non-return valve directly on the main cylinder prevents lowering of the machine in the event of a loss of compressed air pressure; the valve opens only when the Start button is pressed, see Pneumatic circuit diagram chapter 10.1
- The motor does not run during insertion
- Protection against contact with the drill bit (vertical)

5.4 Sticker Description



Danger!



Risk of crushing

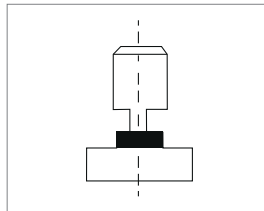

Valve for clamping cylinder

5.5 Purpose

The TECMATOR RP is designed and engineering only for the operations described in chapter 1.3 Intended use. The manufacturer guarantees the proper function of the machine for all these applications. Use for any other purpose may result in injury to the operating personnel or in damage to the machine or workpieces.

5.6 Identification of the Product

All machines bear a rating plate on which the year of manufacturer, machine number, machine type, rated voltage and frequency and the necessary compressed air pressure can be found. A sticker with the machine designation can also be found on the motor bracket.

6.0 Standard specification

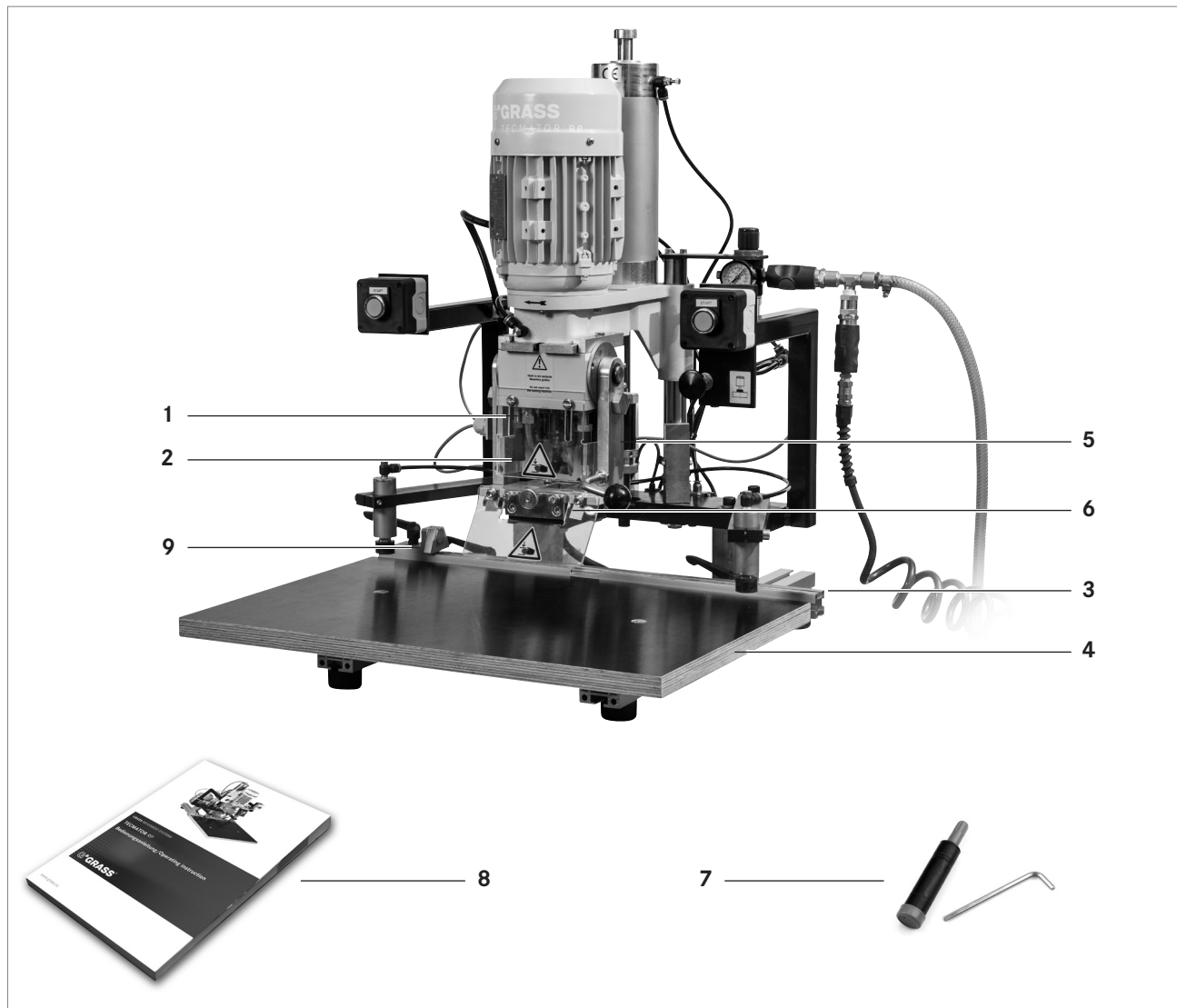

Standard Specification

1. 6-spindle drilling head with chuck
2. Drill bits for hinge drilling pattern (1 x 35 mm and 2 x 10 mm or 2 x 8 mm diameter)
3. Combined stop and ruler, 600 mm long
4. Wood supporting table, 600 mm wide and 400 mm deep
5. Insertion die arm to hold the insertion die
6. Standard die for all common hinges
7. Grease gun, Allen keys, open-jaw spanners 10, 13+17
8. Operating manual
9. Side stop left and right

7.0 Description of machine parts

7.1 Overall View with Part Numbering

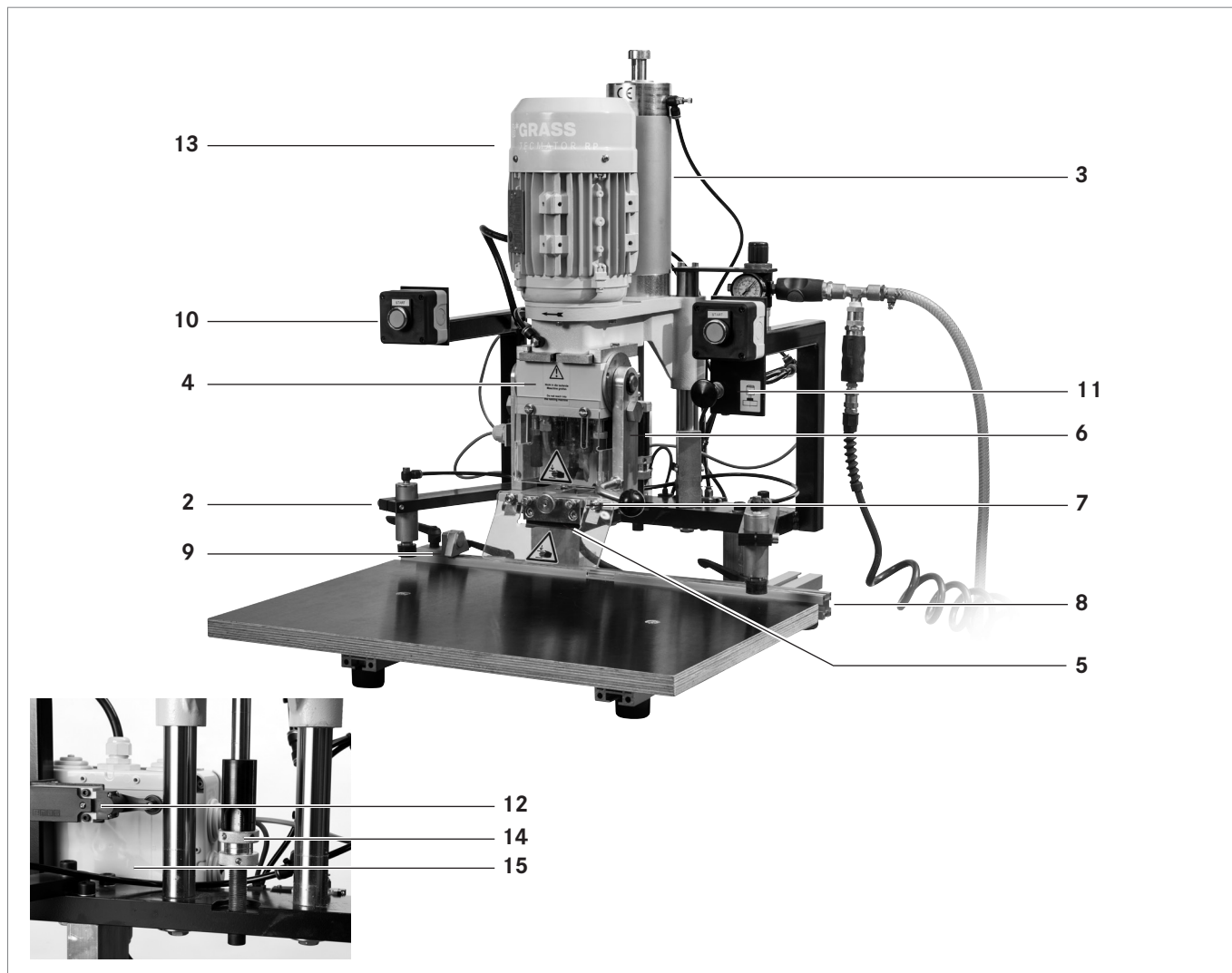

Main Components

- 01 Air conditioner, chapter 20
- 02 Hold-down devices
- 03 Lift cylinder
- 04 Drilling gear
- 05 Die
- 06 Swivel arm
- 07 Pressure plate
- 08 Combined stop and ruler
- 09 Folding stop
- 10 Start button, 2-hand control
- 11 Control valve for hold-down devices
- 12 Cylinder position switch
- 13 Electric motor
- 14 Drilling depth adjustment
- 15 Electrical terminal box

8.0 Gearbox hole patterns TECMATOR RP

Depending on the version selected, the standard gearbox and the drill bits supplied can be used to drill the following hole patterns:

TECMATOR RP Drilling Template

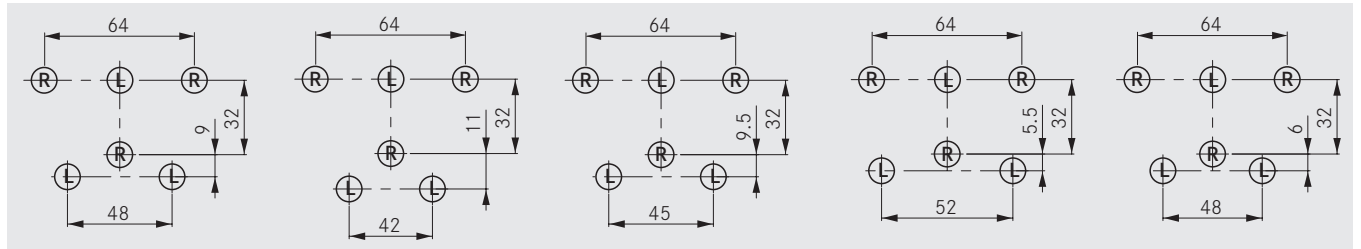

Note: 5 mm drill bits for 32 mm hole spacing are not included in the standard scope of supply.

9.0 Description of the operating elements

Start buttons for the vertical lifting movement



Pressing the two buttons simultaneously starts the vertical drilling or insertion operation. Manipulation of the 2-hand control unit are dangerous and not permitted.

Your hands must not be in the danger area of the drill bits, hold-down devices or insertion die when operating the 2-hand control unit. After a defined travel distance, the drill motor is started automatically. Both buttons must remain pressed until the drill has reached the end position (stop). Releasing the buttons earlier causes the drilling head to move up again.

Selector switch for pneumatic hold-down devices



The hold-down devices can be controlled with the right-hand valve.

Pulling

the knob causes both hold-down devices to lower. To release the hold-down devices, press the knob in again. The hold-down devices must be adjusted to the workpiece height.

The available stroke is limited to 5 mm!

- Pulled position = Workpiece clamped
- Pressed position = Workpiece released

10.0 Circuit diagrams

10.1 Pneumatic Circuit Diagram

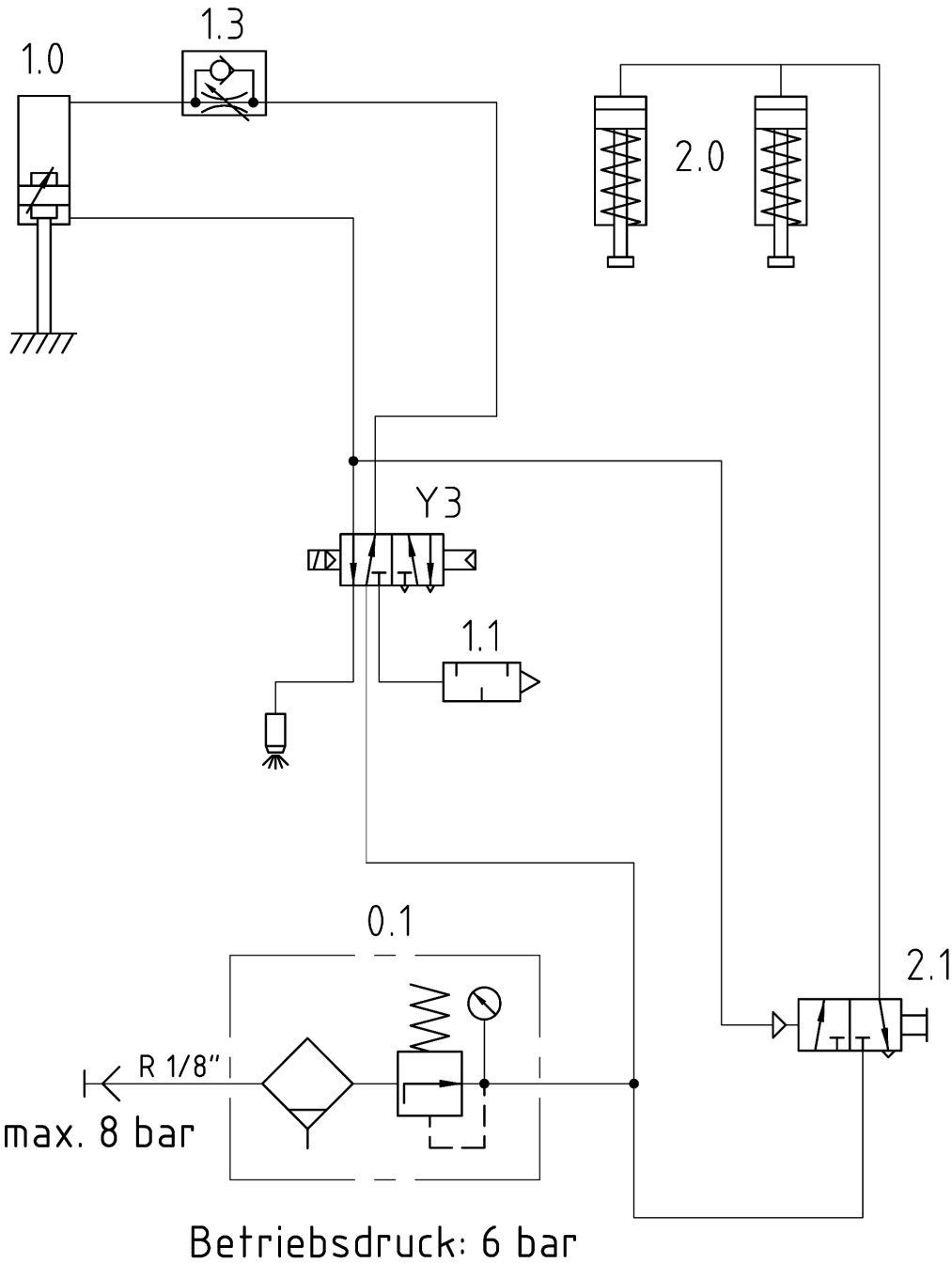

10.2 Electrical Circuit Diagram

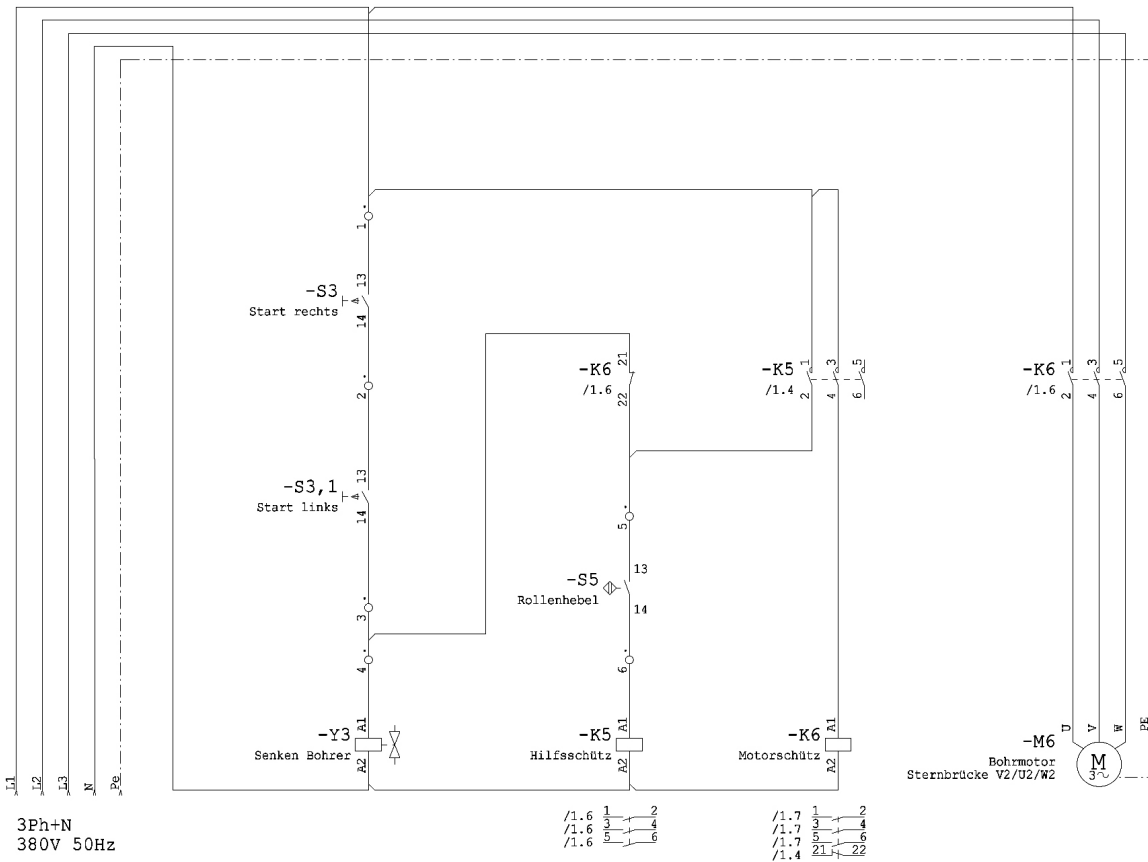
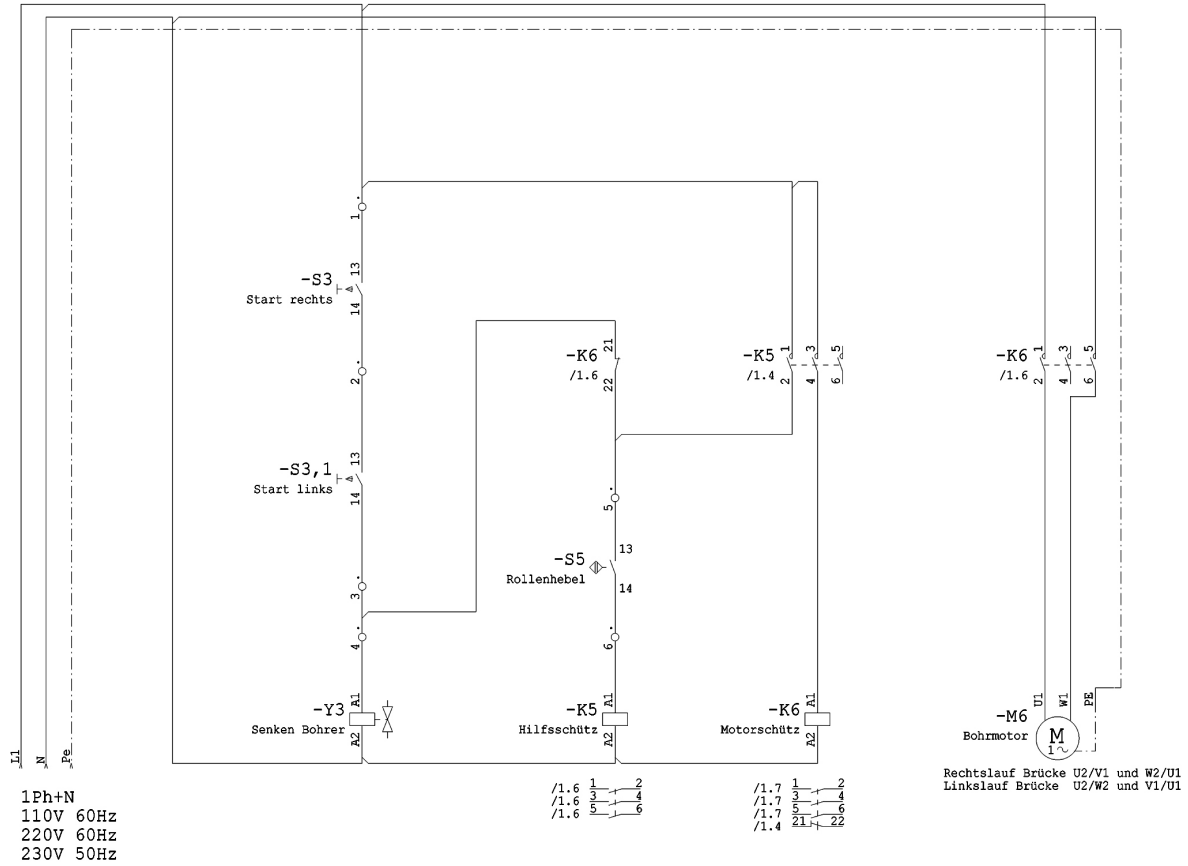

11.0 Transport, installation and final adjustment

The Tecmator RP is delivered together with all the accessories. The machine must be installed in a stable position on a sufficiently large table surface (beyond the dimensions of the machine).

Align the machine at its final installation location using a spirit level.



Important!

The machine must not be lifted at the machine table (aluminium profiles) as otherwise the machine settings could be changed.

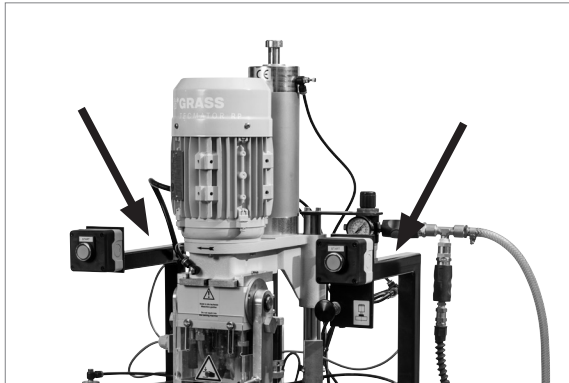

Carry the machine only at the strut.

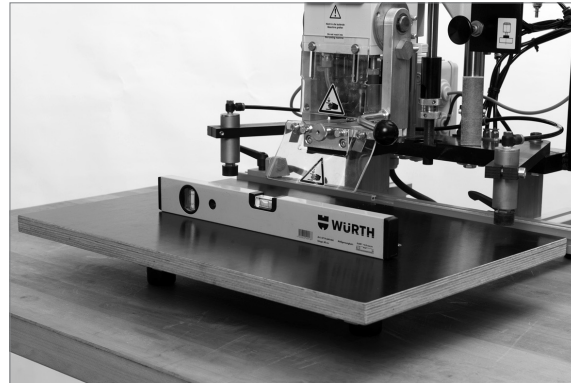

Align the machine using a spirit level.

11.1 Scope of Supply

- Inspect the machine after unpacking for possible damage.
- Report any damage discovered to the supplier immediately.
- Check the scope of supply immediately after unpacking. Simply compare the goods with the delivery note for correspondence.
- Report any missing parts discovered to the supplier immediately

11.2 Transport and Storage Conditions

- Protect the machine against moisture and wetness during transport and storage.
- Storage temperature from -20°C to $+50^{\circ}\text{C}$.

11.3 Space Requirements and Ambient Conditions

- The space required depends on the size of the workpieces to be handled.
- The minimum dimension for the depth is approx. 80 cm.
- The minimum dimension for the width is approx. 100 cm, plus an additional 100 cm per extension ruler and side.
- The machine must be installed in a dry room where it is protected against moisture and wetness.
- The ambient temperature during operation of the machine should lie in the range of $+10^{\circ}\text{C}$ to $+40^{\circ}\text{C}$.
- The relative humidity should lie in the range of 10% to 80% , non-condensing. Large deviations can lead to malfunctions in the operation of the machine.

12.0 Accessories

DRILL BITS WITH 10 MM SHANK DIAMETER

	Drill bit length	Drill bit diameter	Anticlockwise (red)	Clockwise (black)
	50	2.7	F146135822201	F146135823201
	57	5	F146135824201	F146135825201
		8	F146135826201	F146135827201
		10	F146135828201	F146135829201
		35	-	F146135830201

ACCESSORIES

	Description	Article No.
	7-spindle vertical drilling gear with integrated rig pins for drilling hole series in the 32 mm system (drill bits not supplied)	F146135811201
	Side stop left or right	F146135810201
	Extension ruler, 800 mm left	F146135831201
	Extension ruler, 800 mm right	F146135832201
	Universal insertion die for Nexis and Tiomos 110° and 160° hinges (other dies upon request)	F146135821201
	Quick-release chuck, left	F146135835201
	Quick-release chuck, right	F146135836201
	Hold-down device extension, hydraulic hose extension	F146135867201

13.0 Commissioning

13.1 Pneumatic Connection

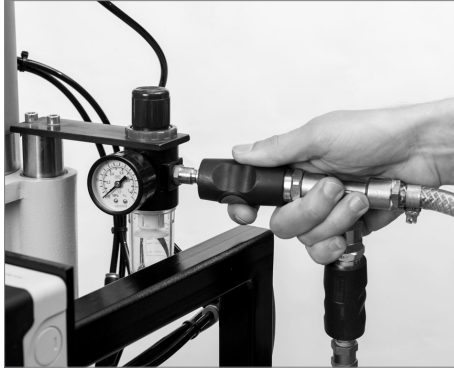

Connect a hose with an inside diameter of 6 mm to the air conditioner. The hose must be fitted with a shut-off valve or coupling at a maximum distance of 1.5 metres to the Tecmator RP.

Recommended air pressure 6 bar, air consumption per stroke approx. 1.8 litres. The compressor should have a tank capacity of at least 100 litres and an intake capacity of 200 litres/min. If the machine is not connected to the compressed air grid by means of the coupler provided, a shut-off device must be installed near the operator.

13.2 Removal of the Drop Arrester



Before commissioning, remove the drop arrester at the guide.



Important!

Compressed air must be connected before the drop arrester is removed.

13.3 Function Te

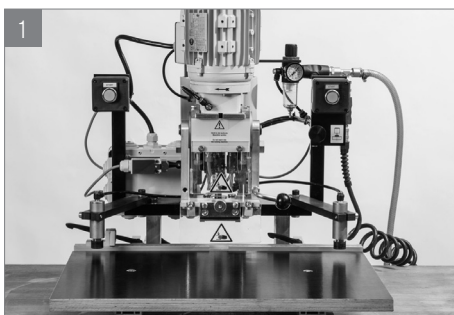

1 Connect the machine

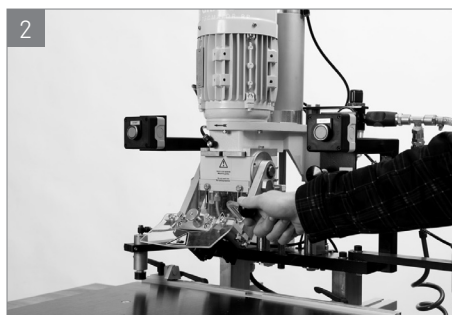

2 Push the insertion die arm up



3 Press the Start buttons (the motor bracket moves downwards).

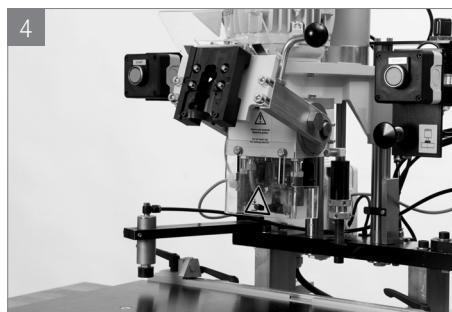

4 Release the Start buttons (the motor bracket moves back to its starting position)

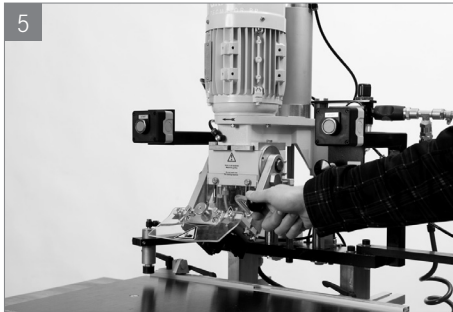

5 Push the insertion die arm down



6 Press the Start buttons (the motor bracket moves downwards)

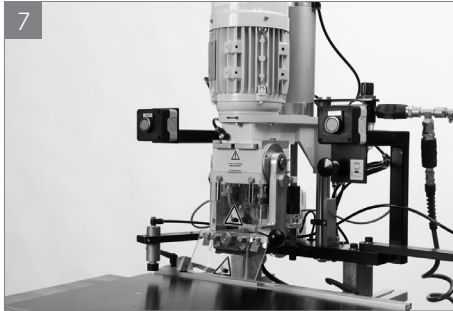

7 Release the Start buttons (the motor bracket moves back to its starting position)



Contact the manufacturer if the function test was not successful.

13.4 Electrical Connection

The electrical connection of the machine may only be made by authorised electricians in accordance with the national regulations. The machine is delivered fitted with a Cekon plug according to the ordered voltage. The plug socket must be freely accessible, at a suitable working height and in the vicinity of the operator.



Attention:

The direction of rotation of the motor must correspond to the arrow on the drilling head bracket.



Danger!

Danger from electric voltage.

Disconnect the machine from the electrical power supply before starting any work on the electrical system.

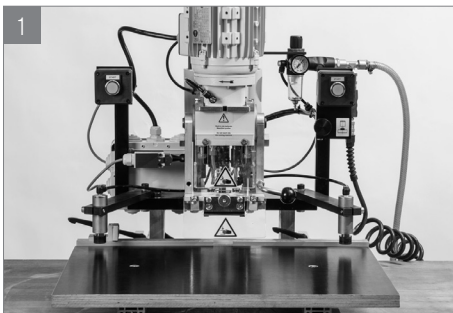

1 Connect the machine

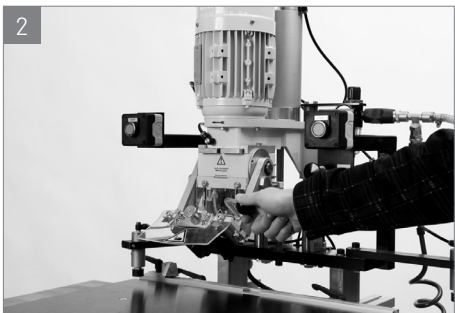

2 Push the insertion die arm up



Press the Start buttons (the motor bracket moves downwards).

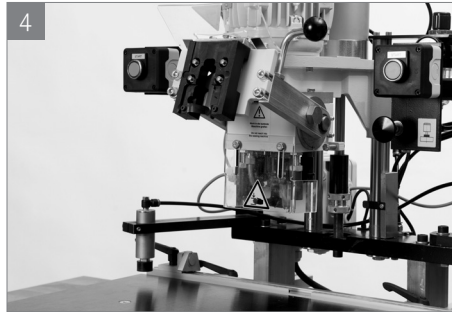

Release the Start buttons (the motor bracket moves back to its starting position).

14.0 Working with the TECMATOR RP

14.1 Requirements for the Operating Personnel

- This machine may only be operated by persons who are familiar with the handling of the machine.
- This know-how can be gained through a thorough training by persons familiar with the handling of the machine, or by thorough studying of this operating manual.
- The operating personnel must be capable of operating this machine.
It is the responsibility of the machine owner to check whether the operating personnel is operating the machine in accordance with this operating manual.
- The owner of the machine is responsible for ensuring compliance with these instructions.

15.0 Set-up of the TECMATOR RP

15.1 Chucking the Drill Bits

Tools required: Allen key 2.5 mm

- Loosen retaining screw 1 using a 2.5 mm Allen key
- Push in the drill bit up to the stop, paying attention to the flat surfaces of the drill bit
- Tighten the retaining screw



Attention:

Always be sure to remove empty drill chucks because empty drill chucks can result in gearbox damage due to the loose retaining screws; this damage is not covered by the warranty.



Loosen the retaining screw.



Insert the drill bits and tighten.

15.2 Installing an Insertion Die

The TECMATOR RP is delivered with an insertion die already fitted. If the die needs to be replaced, proceed as follows:

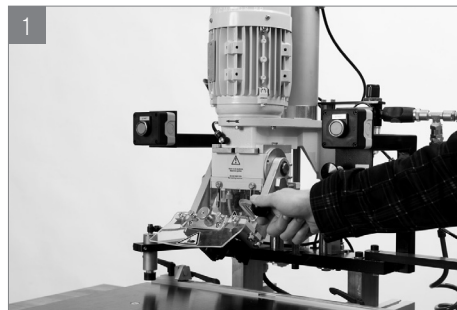

1 Push the insertion die arm up



2 Loosen the clamping screw at the insertion die

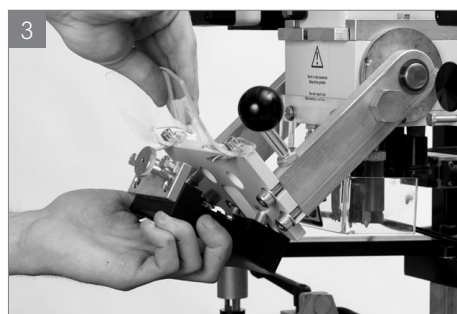

3 Hook the die in/remove the die, with the clamping screw first



4 Tighten the clamping screw by hand

15.3 Setting the Drilling Depth

The machine is set at the factory to a drilling depth of 13 mm, referred to a board thickness of 13 mm.

Drill bits

In the original depth condition, the drill bits have a length of 57 mm. If the length is reduced due to resharpening, this can be compensated at the adjustment screw.

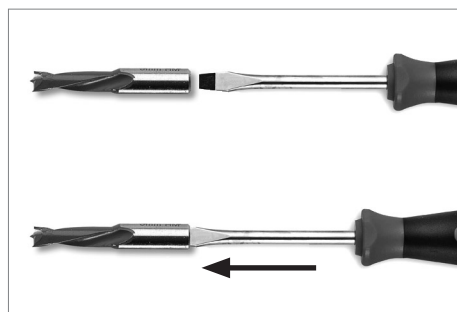

The length of the drill bit can be compensated at the adjusting screw

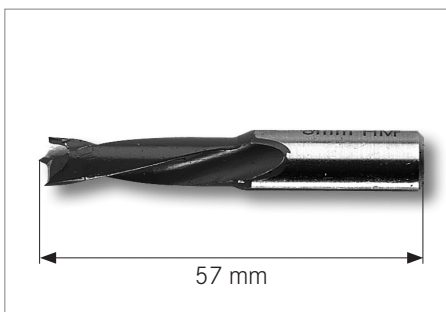

The length of the drill bit should be 57 mm

Knurled screw

The drilling depth is adjusted according to the scale using the knurled screws on the piston rod and locked with the second knurled screw. The depth mark for the quick-release chuck (78 mm) is the knurled screw, for chuck (71 mm) the depth mark is the stamped mark (ring, 7 mm from the bottom) on the intermediate tube. The scale indicates in each case the clearance between tool support and drill bit.

Board thickness (16 mm) – drilling depth (13 mm) = Setting on the scale (3 mm)

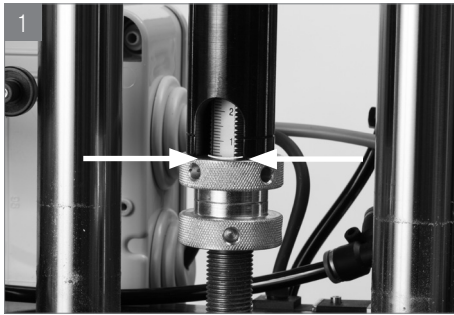

Depth mark for quick-release chuck.

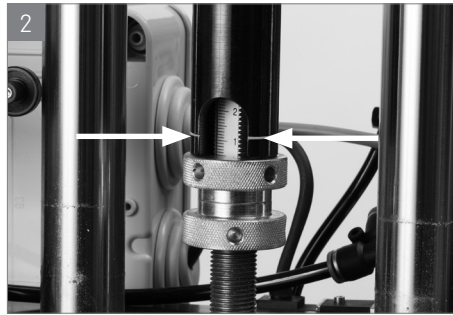

Depth mark for chuck.

15.4 Setting the Drilling Distance

The edge or depth setting is made by moving the combined stop and ruler along the guide rails on the side of the machine table. First release the two clamping levers on the guide section. The desired edge distance can be read off from the scales on both sides of the combined stop and ruler. After adjustment, tighten the clamping levers again.

The scale shows the distance from the middle of the main spindle.

On the left and right of the guide rail are stops for the two most common edge distances (measure to the screw head, not to the washer) with preset distances.

- A: Distance of hinge from edge = 22 mm (C = 4.5 mm)
- B: Distance of holes from edge = 37 mm

The stop bolts are set to the above positions at the factory. They can, however, also be adjusted as necessary to meet the needs of the user.

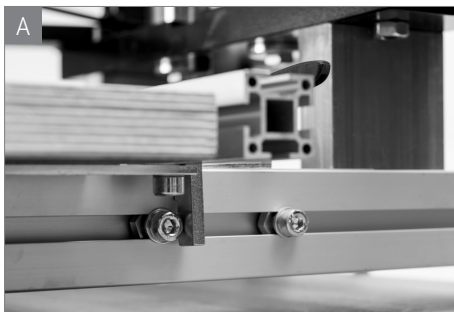

Press in stop pin for hinge bore and hinge.

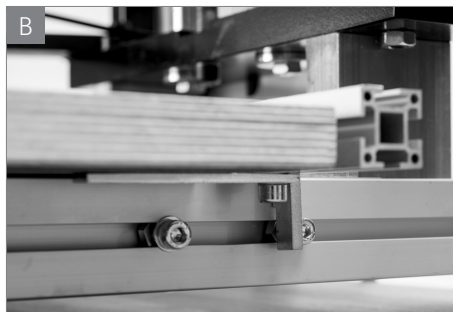

Stop pin for drilling rows of holes.

15.5 Adjustment of the Side Stops

The combined stop and ruler is adjusted at the factory to 0 relative to the centre of the main spindle so that the stops can be adjusted exactly using the millimetre or inch scale. First loosen the clamping lever, then tighten again after adjustment.

If workpieces with rounded or profiles edges are to be processed, the stops can be used here, too, by changing the left to the right-hand side and the right to the left-hand side. The reference edge for the setting dimension on the scale is always the stop side of the pendulum.

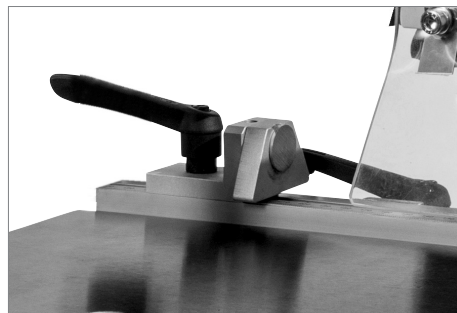

Side stops can be adjusted.

15.6 Adjustment of the Hold-down Devices

The hold-down device is suitable for a wide range of material thicknesses and can be used on both left and right-hand sides of the machine.

Adjustment of the Hold-down Devices

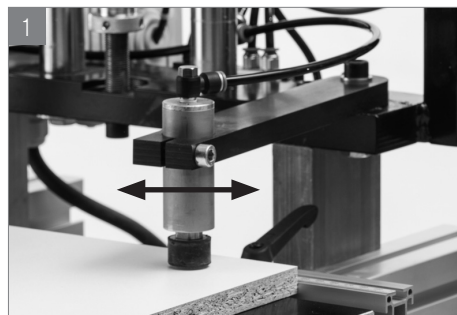

1 Move the hold-down device to the desired position.



2 Loosen the hold-down devices at the clamping screw.

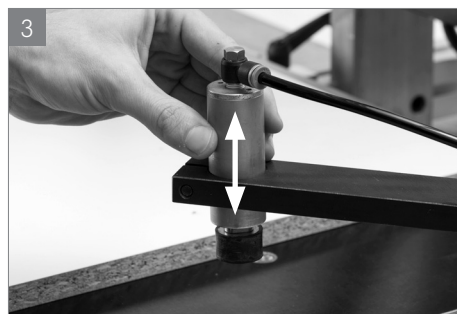

3 Adjust the height of the hold-down devices and tighten the clamping screw again.

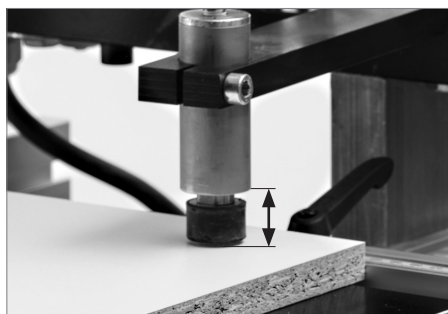

Attention: The available stroke is limited to 5 mm!

16.0 Drilling and insertion for the Grass TIOMOS hinge

1. In the front spindle row, install one 35 mm drill bit (clockwise rotating, black) and two 10 mm or 8 mm drill bits (anticlockwise rotating, red) (depending on the drilling pattern).
2. Adjust the drilling depth according to the scale using the knurled screw on the lift rod and tighten knurled screw again.

Board thickness – drilling depth = Setting on the scale

3. Loosen the clamping levers on the guides of the combined stop and ruler and press the combined stop and ruler forward against the dead stops. Tighten the clamping levers again. Edge distance 22 mm (cup distance = 4.5 mm) is now set.
4. Adjust the folding stops to the desired distance according to the scale.



Attention

Carry out a test drilling!

5. Insert a workpiece and press against the combined stop and ruler und folding stop.
6. Adjust the hold-down devices (to workpiece height) and clamp the workpiece.
7. Start the drilling operation with the 2-hand control and release to stop the drilling operation.
8. Place a hinge into the die and swing the hand lever down over the drilled hole.
9. Start the insertion operation with the 2-hand control and release to stop the insertion operation.



If the hinge is not pressed completely flush into the cup bore, this can be due to the pressing angle of the hand lever. The pressing angle can be changed at the adjusting screw on the hand lever (see figure below).

10. Push the hand lever down, release the hold-down devices and remove the workpiece.

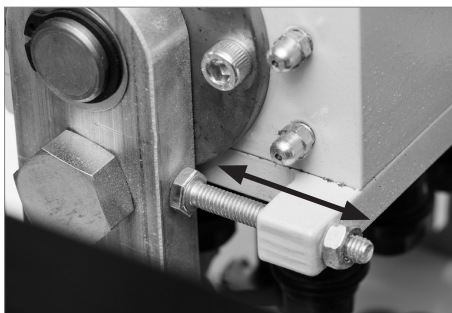

Hand lever adjusting screw for insertion angle.



1 Chuck drill bits.

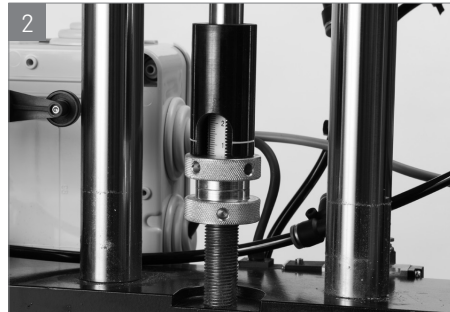

2 Set drilling depth.

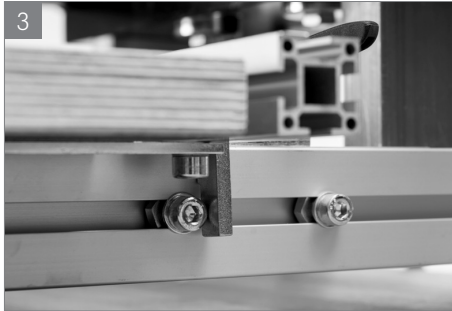

3 Loosen clamping levers, pull table forwards.

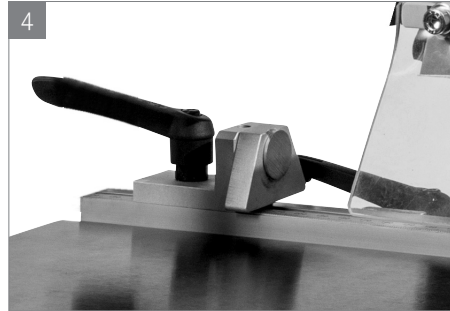

4 Adjust the folding stops.



5 Press workpiece against the stop.



6 Clamp the hold-down devices.



7 Perform drilling operation.



8 Insert hinge, press hand lever downwards.

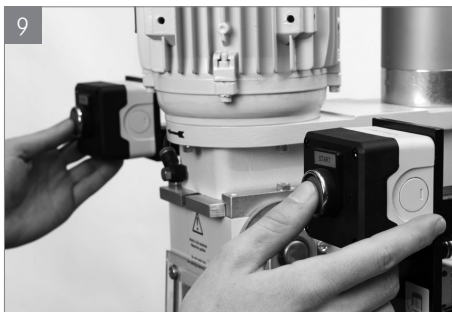

9 Start insertion operation.



10 Pull hand lever up, remove workpiece.

17.0 Drilling the 32 mm hole spacing

1. Install a 5 mm drill bit (optional accessory) into the rear drill chucks.
2. Adjust the drilling depth according to the scale using the knurled screw on the lift rod and tighten knurled screw again.

Board thickness – drilling depth = Setting on the scale

3. Loosen the clamping levers on the guides of the combined stop and ruler and press the combined stop and ruler back against the dead stops. Tighten the clamping levers again. Edge distance 37 mm is now set.
4. Adjust the folding stops to the desired distance according to the scale.



Attention

Carry out a test drilling!

5. Insert a workpiece and press against the combined stop and ruler und folding stop.
6. Adjust the hold-down devices (to workpiece height) and clamp the workpiece.
7. Start the drilling operation with the 2-hand control and release to stop the drilling operation.
8. Release the hold-down devices and remove the workpiece.



1 Chuck drill bits.

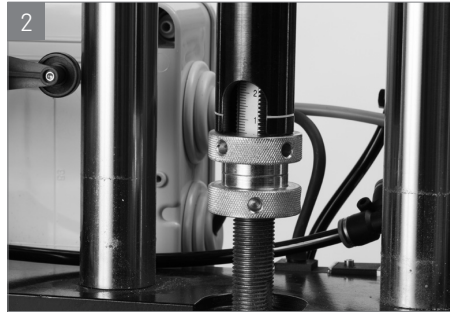

2 Set drilling depth.



3 Loosen clamping levers, push table to the rear.

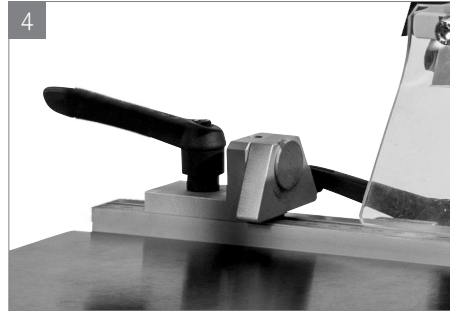

4 Adjust the folding stops.



5 Press workpiece against the stop.



6 Clamp the hold-down devices.

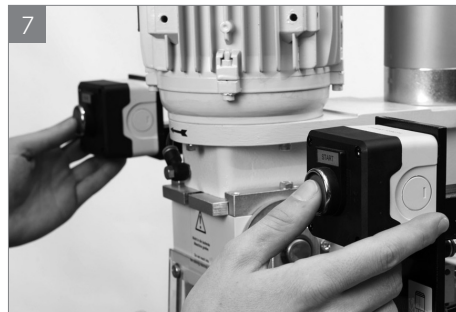

7 Start drilling operation.

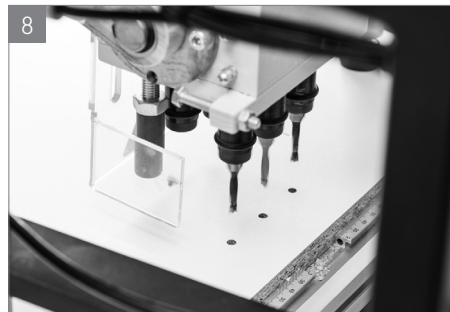

8 Remove workpiece.

18.0 Replace machine parts

18.1 Replacement of Drilling Gear



1
Disconnect the machine from the compressed air supply.



2
Loosen the gearbox using a ring spanner and pull out to the front.

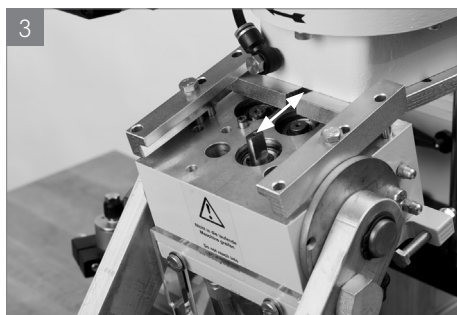

3
Insert gearbox and push to the rear. Tighten using a ring spanner.



Attention!

Pay attention that the drill bits are turned so that the drilling spindle on the gearbox head is facing towards the gearbox guide. This applies to both installation and removal of the gearbox, otherwise the gearbox cannot be moved.

18.2 Installing Hold-down Device Extension

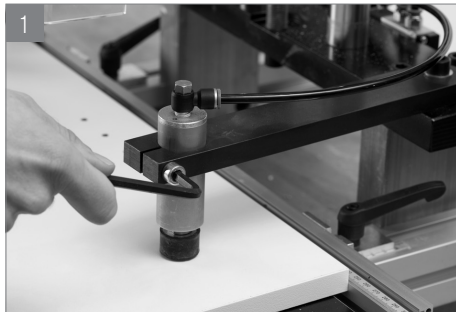

Loosen and pull out hold-down device.



Insert hold-down device extension into the hole and tighten.



Connect the extended compressed air hose to the hold-down device.

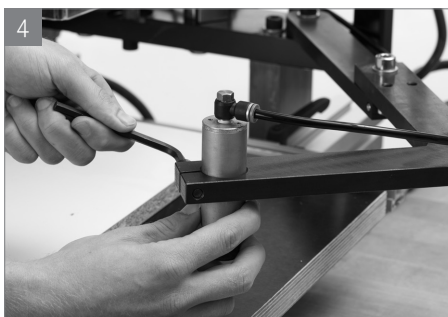

Push hold-down device into the extension and adjust to workpiece height.

19.0 Troubleshooting

The following overview provides information on faults, their causes and remedies.
If the fault cannot be remedied in spite of the table, please contact your dealer.

Fault	Possible causes	Remedy
Machine does not move	No compressed air supply	➔ Check the compressed air supply; the pressure gauge must show 6 bar
The motor does not start	No contact	➔ Press the insertion die arm completely upwards
	No electric power supply	➔ Connect the electric power supply
The motor rotates, but the tool does not	Coupling defective	➔ Replacement only by service personnel, contact the manufacturer
Tool rotates in the wrong direction	The 3-phase AC power supply is incorrectly connected	➔ Check the motor direction of rotation, phase reverse may only be replaced by qualified personnel
	Tools wrongly fitted	➔ Install the tools correctly, red = anti-clockwise, black = clockwise
Bores are frayed	Blunt tool	➔ Replace with a sharp tool
Bores are not round	Clamping levers on gear unit are loose	➔ Tighten the clamping levers on the gear unit
Hinge is not pressed in cleanly	Insufficient compressed air pressure	➔ Direct drives in completely enclosed gear housings
	Insertion position not correct	➔ Pay attention to the correct insertion position

20.0 Maintenance and care

The machine must be disconnected from the electrical power supply and compressed air supply for service and maintenance.

Drilling head

The drilling head must be lubricated every 40 to 50 operating hours via the grease nipples on the side (3 to 4 strokes of the grease gun)

Pneumatic valves

At the same intervals, 10 to 15 drops of commercially available hydraulic oil (Hpl 46) have to be injected into the supply line (coupling).

Water trap

The water trap has to be drained at regular intervals by opening the pressure valve (once a week). Then every two weeks, inject a small amount (approx. 10 drops) of commercially available HP oil into the port of the air conditioner.

Drill shank

Grease the drill shanks lightly before inserting into the drill chuck.

Machine

The machine proper must be cleaned once a week or as required.

Checking the Safety Functions

The safety functions must be checked every day:

- Press both buttons → All cylinders are extended
- Release the buttons → All cylinders are retracted

If other reactions than those described occur, the machine must be stopped immediately and disconnected from the electrical power supply and compressed air supply.

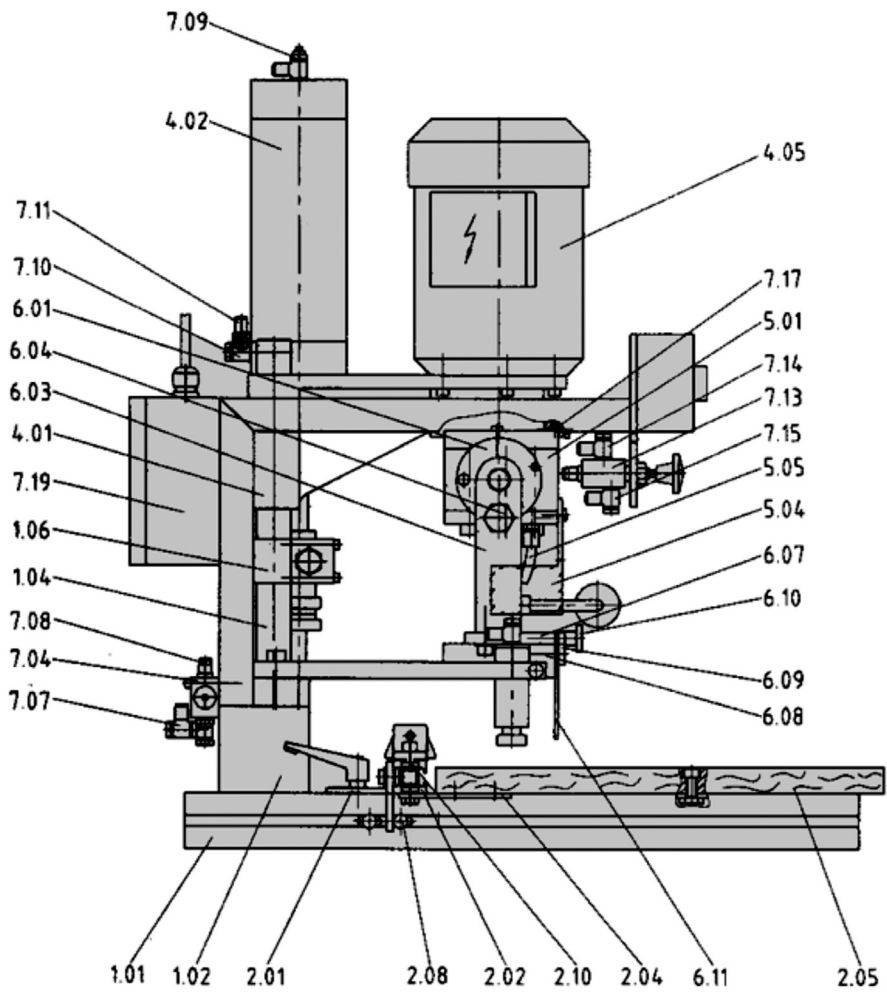
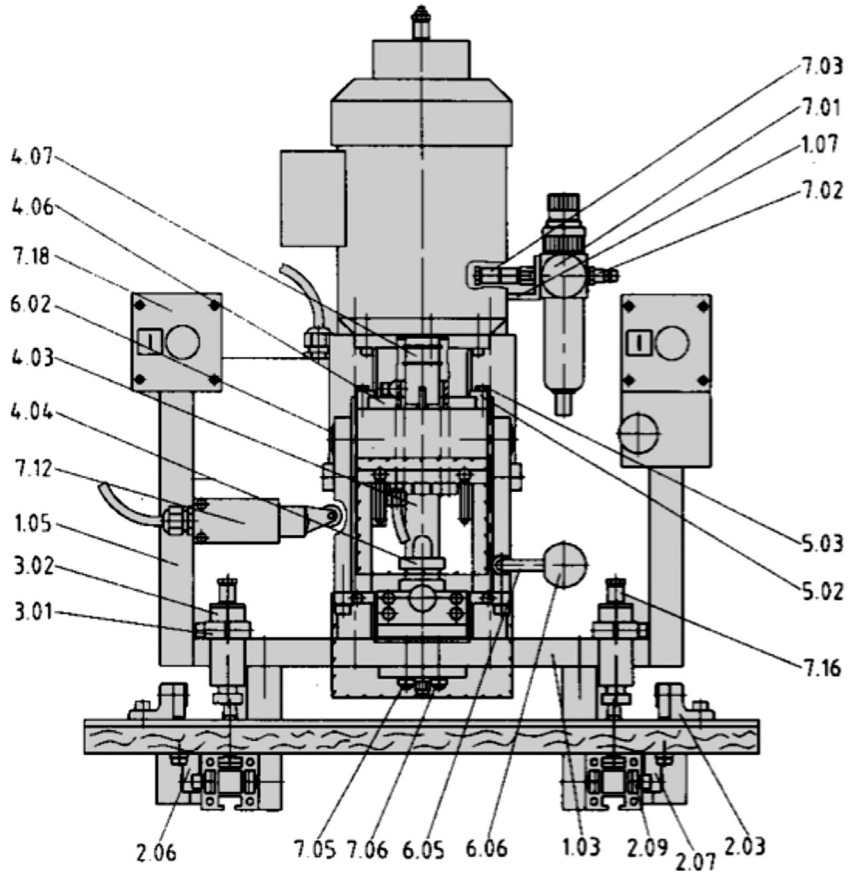

21.0 Individual parts of the Tecmator RP

Machine stand

1.01	Aluminium profile 50 X 50 X 600
1.02	Mounting
1.03	Bridge
1.04	Guide shaft
1.05	Bracket for electric controller
1.06	Bracket for limit switch
1.07	Bracket for pressure regulator

Stop device

2.01	Angle – Al profile
2.02	Al profile 30 X 30 X 600
2.03	Stop flap
2.04	Connecting rail
2.05	Wooden support
2.06	Stop
2.07	Stop
2.08	Slide block
2.09	Slide block

Workpiece clamping

3.01	Clamping cylinder holder
3.02	Clamping cylinder

Drilling and insertion

4.01	Drilling head bracket
4.02	Lift cylinder
4.03	Adjusting ring
4.04	Knurled nut
4.05	Electric motor
4.06	Cover
4.07	Driver

Drilling head

5.01	Drilling head
5.02	Guide rail
5.03	Hexagon head bolt
5.04	Protective hood
5.05	Blow-out tube

Swivelling and insertion device

6.01	Washer
6.02	Bolt
6.03	Swivel lever
6.04	Hexagon head bolt
6.05	Handle
6.06	Ball knob – DIN 319
6.07	Thrust plate
6.08	Die
6.09	Plate
6.10	Knurled screw
6.11	Guard
7.0	Controller
7.01	Pressure regulator with water trap – G 1/8 i (No. 0.1 in circuit diagram)
7.02	Coupling – R 1/8"
7.03	Swivel fitting – R 1/8"
7.04	5/2-way valve – 0 820 022 990 (Bosch) (No. Y3 in circuit diagram) (with solenoid coil – 1 824 210 236)
7.05	Silencer – 1/4" (No. 1.1 in circuit diagram)
7.06	Silencer – 1/4" (No. 1.2 in circuit diagram)
7.07	Swivel fitting – R 1/8"
7.08	Screw fitting – R 1/8"
7.09	Throttle screw B – R 1/8" (No. 1.3 in circuit diagram)
7.10	Automatic air vent – Type SEV 10 – R 1/8" (No. 1.4 in circuit diagram)
7.11	Swivel fitting – R 1/8"
7.12	Limit switch with swivel lever – 3SE2120 – OWG (Siemens)
7.13	Hand valve with pneumatic reversing – Type 3/2 HK 101.1-PU (No. 2.1 in circuit diagram)
7.14	Swivel fitting – R 1/8"
7.15	Swivel fitting – R 1/8"
7.16	Swivel fitting – R 1/8"
7.17	Swivel fitting – R 1/8"
7.18	Push-button (green) – 3 SB 1801 – 7AA (Siemens)
7.19	Switch housing with coupling protection – 3TG10 01 – OAL2 with fine fuse 2A-Tr)

GRASS GmbH & Co.KG
Egerländer Str. 2
64354 Reinheim / Germany

22.0 Declaration of Conformity

pursuant to Directive 2006/42 EC (Machinery Directive) Annex II A

We hereby declare that the following machine

Make / Type Designation	GRASS-TECMATOR RP
Serial No.	15102_RP

complies with all the relevant provisions of Directives **2006/42 EC** and **2004/108/EC**.

Reinheim, 09.03.2015

 **GRASS**
Grass GmbH & Co. KG
Egerländer Straße 2
D-64354 Reinheim



GRASS GmbH
Movement Systems
Egerländer Str. 2
D 64354 Reinheim, Germany
Tel.: +49 (0)6 162 802-0
Fax.: +49 (0)6 162 802-221
E-mail: info@grass.eu